

Z-1996/ MB-2600 MOP BASIN INSTALLATION AND MAINTENANCE INSTRUCTIONS

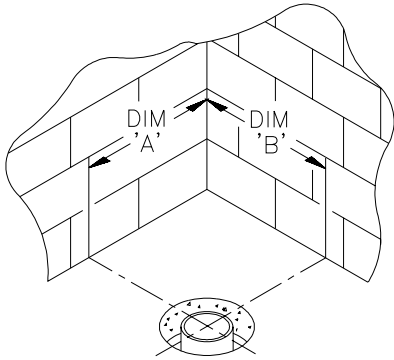

MOP SINK	DIM 'A'	DIM 'B'
24 x 24	12-1/16 (307 mm)	12-1/16 (307mm)
24 x 36	18-1/16 (459 mm) 12-1/16 (307 mm)	12-1/16 (307 mm) 18-1/16 (459 mm)

1. EXCAVATION

Locate center of the drain pipe according to what size mop sink is being used and how it is positioned. Refer to the drawing and chart above for this information. It is important to leave a 6" diameter pocket in the concrete, around the drain pipe to allow for the drain body.

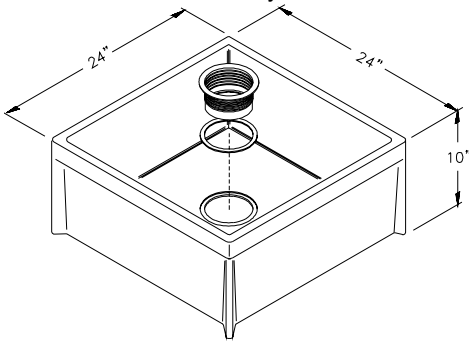
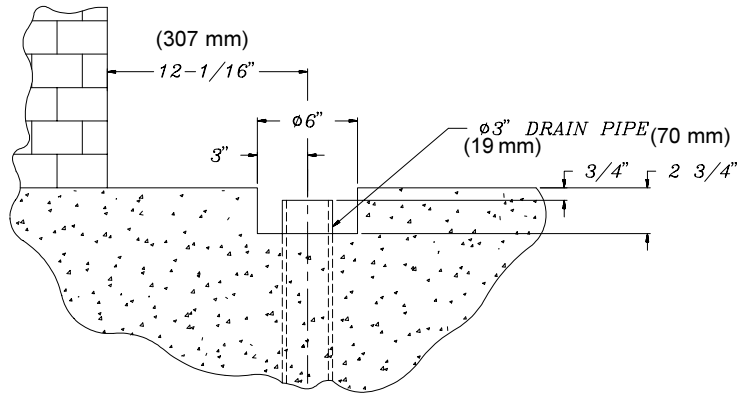

2. ASSEMBLY & INSTALLATION

The stainless steel drain bodies are factory installed. The PVC drain bodies are assembled at the job site. Once the drain body is installed, carefully place the mop basin in the designated area aligning the drain body with the drainpipe (lubricating the drainpipe with soap or petroleum jelly will ease the gasket alignment). Secure the gasket around the drain pipe with the compression ring and disposable wrench provided. Replace the stainless steel strainer and fasten with the two screws provided. Once the mop basin is in place, seal all sides with a silicone caulking.

3. MAINTENANCE

In order to uphold the longevity of the ZURN LIGHT COMMERCIAL mop sink. It should be rinsed out or wiped down after every use and periodically cleaned with a non-abrasive mild detergent.

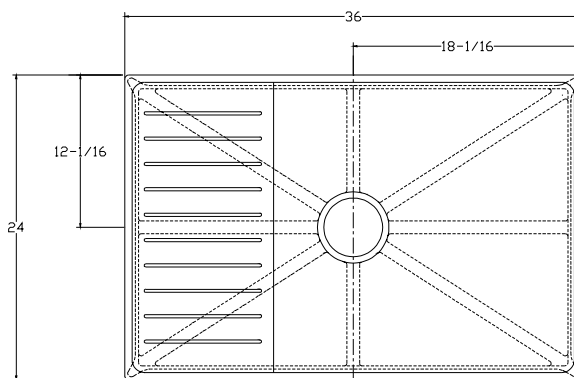
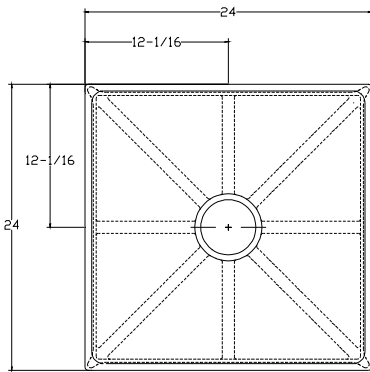

Form # JS39 Date: 4/11/02
C.N. No. 89102 Rev. C



Warranty

No warranty is implied or given. Zurn Light Commercial shall not be responsible for any labor charges or any loss, injury or damages whatsoever, including incidental or consequential damages. Zurn Light Commercial agrees to repair or replace any part or parts which examination, by an authorized Zurn Light Commercial representative, proves to be defective in workmanship or material, within one year from date of purchase. This guarantee does not include the repair or replacement required because of misuse, abuse, or excessive wear and tear. Repairs made by anyone other than a designated representative relieves Zurn Light Commercial of further liability under this guarantee.