



**MERCEDES  
TEXTILES LIMITED**  
Innovation delivered.™

## FORESTRY PRODUCTS



[mercedestextiles.com](http://mercedestextiles.com)





## ABOUT OUR COMPANY

Since our inception in 1978, our vision has been to manufacture the finest, most durable and highest performing hose products in the world. Dedication, hard work and a series of critical decisions helped us to realize our objectives in a relatively short period of time. Across the spectrum, proactive thinking, unrivaled advancement and continued customer acceptance are the qualities that set Mercedes Textiles Limited apart. We hold over 60 patents and have grown into three facilities producing a vast array of products sold worldwide. Fueled by the early creation of innovative product offerings, we created Hydro-Wick®

Industries Inc. in 1995. This production facility focuses on the manufacture of high-pressure pumps, advanced coupling systems and technology enhanced, wildland firefighting products.

The next year, in 1996, we continued to expand with the formation of High-Water Hose Inc. to extend our product offerings to include a wide range of rubber covered and lightweight, lay-flat hose.

Today Mercedes Textiles is widely recognized as the world's leader in innovative municipal, forestry, snowmaking and industrial fluid delivery systems and specialty equipment. A relentless focus on research and development continues to be at the forefront of our growth strategy. Mercedes Textiles Limited has come a long way yet we remain just as committed to improving, redefining and transforming our industry as we did when we first began.

# ABOUT OUR PUMPS

Since our inception in 1978, our vision has been to manufacture the finest, most durable and highest performing water delivery products in the world.

Firefighters prove themselves on the fireline every day, facing whatever the wild demands head-on.

And that is exactly what we engineer our WICK® pumps to do — deliver unrivaled endurance, versatility and reliability when you need it.

Innovators at our core, we created Hydro-Wick® Industries Inc. in 1995 to focus on manufacturing high performance pumps, advanced coupling systems, and other wildland firefighting products.

This is where the WICK® product line was born.

We've sold over 5000 of our world-renown single-stage pumps since their debut in 1998, and we didn't stop there.

Mercedes Textiles Ltd. now offers a full lineup with over 20 portable pumps of different weight classes, performance levels, and configurations to fit your fight.

Built on over 45 years of innovation, WICK® pumps are proven to outperform and outlast under the toughest conditions, when it matters most.

When the fight demands water, we deliver.

# FIRE PUMPS ULTRA LIGHTWEIGHT

17-20 LBS / 8-9 KG

## ULTRA LIGHTWEIGHT, HIGH PERFORMANCE FIRE PUMP

- Powered by reliable 4-stroke, 50 cc Honda engines, these pumps have the best performance of all pumps in their class
- Integral fuel tank
- Coupled to a bolt-on detachable, single-stage foam-compatible pump
- Standard unique clutch feature for easy starting and water conservation *(Also available without clutch)*
- Single stage, detachable pump end for easy maintenance
- Meets the emission standards of US EPA/CARB regulations
- Optional transportable back pack
- Available with base mounted hand primer
- Available multi-position model with backboard style carrying base

### WEIGHT & DIMENSIONS

Length	14.0"	36 cm
Width	11.0"	28 cm
Height	16.0"	41 cm
Weight*	20.2 lbs	9.16 kg
Suction	1.5" NPSH	38 mm
Discharge	1.5" NPSH	38 mm

### ENGINE

Honda GXH50	4 stroke; 50 cc; 2.5** gros Hp @ 7000 RPM	
Clutch Drive		
Fuel Tank Capacity	0.81 Qt. US	0.77 L
Oil Capacity	.26 Qt US	0.25 L

\* Base model weight (71WICK100-4HA)

\*\* Mass production engines may vary from this value.

Specifications subject to change without notice



## WICK® 100-4H

	Part#	Description
A	71WICK100-4HA	WICK® 100-4H Fire Pump
A	71WICK100-4HLC	WICK® 100-4H Fire Pump .. less clutch
B	71WICK100-4HAP	WICK® 100-4H Fire Pump with base mount hand primer
C	71WICK100-4HAV	WICK® 100-4H Fire Pump with Vertical mount discharge

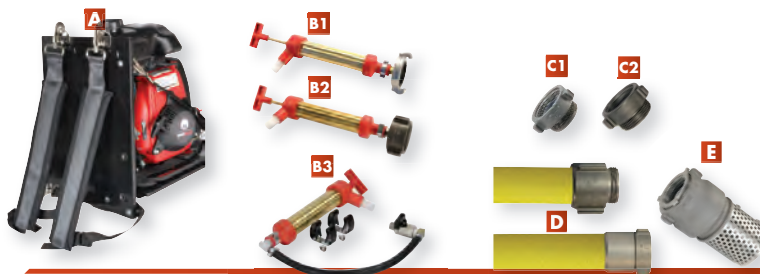

### OPTIONAL

	Part#	Description
A	71W104-HPACK	Back Board with padded carrying straps
B1	70FLHPPQC	Hand Primer QC
B2	70FLHPPPS	Hand Primer NPSH
B2	70FLHPPNH	Hand Primer NH
B3	71W104-PRIMEKIT	Hand Primer kit for WICK® 100-4H
C1	70FL15TPPS	Thread protector 1 1/2" / 38mm
C2	6124NM24PF	Adaptor .. 1 1/2" / 38mm NH Male x 1 1/2" / 38mm NPSH Female
D	70FL15DLPS10	Draftlite HP suction hose .. 1 1/2"/38mm x 10'/3M c/w NPSH *
E	70FLFV15PF	Foot Valve / Strainer (Alum) 1 1/2"/38mm Female NPSH *

\* See website for complete listing of accessory and related products

Performance standard correction as per SAE J1349; 60° F / 15.5° C; Baro 29.92 in. / 101.3 mB

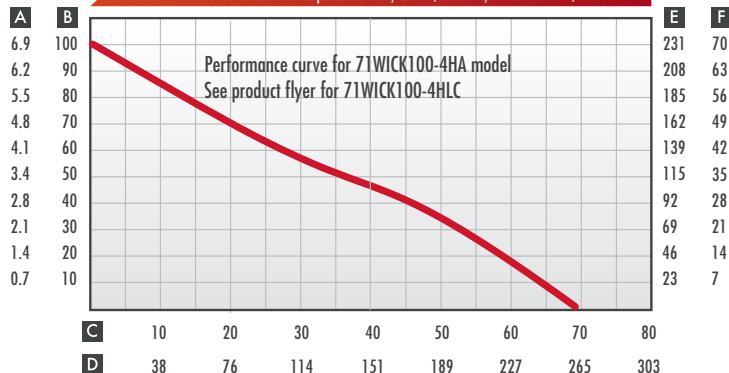

A Pressure in Bar B Pressure in PSI C Flow U.S. GPM D Flow Liters / Min. E Head Pressure Feet F Head Pressure Meters

W100-4H / 120H / 3H



**WICK® 100-4M  
MULTI-POSITION**

Part#	Description
A	71WICK100-4HM WICK 100-4M All position Fire Pump with tubular carrying frame
B	71WICK100-4HMNH WICK 100-4M All position Fire Pump with tubular carrying frame, inlet thread protector and NH discharge adaptor
C	71WICK100-4HMB WICK100-4M All position Fire Pump c/w carrying base
D	71WICK100-4HMBV WICK100-4M All position Fire Pump c/w carrying base, vertical mount discharge
E	71WICK100-4HMBP WICK100-4M All position Fire Pump c/w carrying base, mounted hand primer
F	71WICK100-4HMBPNH WICK100-4M All position Fire Pump with carrying backboard .. c/w hand primer, inlet thread protector and NH discharge adaptor

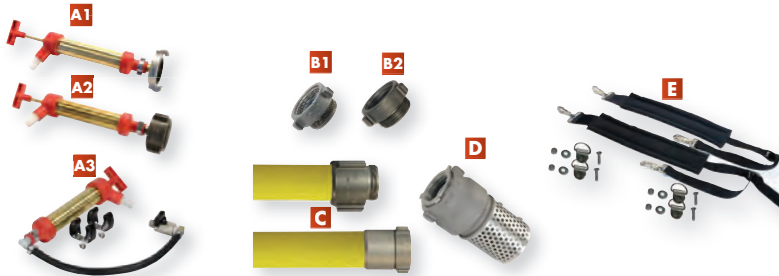

**OPTIONAL**

Part#	Description
A1	70FLHPPQC Hand Primer QC
A2	70FLHPPPS Hand Primer NPSH
A2	70FLHPPNH Hand Primer NH
A3	71W104-PRIMEKIT Hand Primer kit for WICK® 100-4H
B1	70FL15TPPS Thread protector 1 1/2" / 38mm
B2	6124NM24PF Adaptor .. 1 1/2" / 38mm NH Male x 1 1/2" / 38mm NPSH Female
C	70FL15DLPST0 Draftlite HP suction hose .. 1 1/2"/38mm x 10'/3M c/w NPSH *
D	70FLFV15PF Foot Valve / Strainer (Alum) 1 1/2"/38mm Female NPSH *
E	71W104-HMBPACK Backboard padded straps kit for Wick 100-4HM pump

\* See website for complete listing of accessory and related products

Performance standard correction as per SAE J1349; 60° F / 15.5° C; Baro 29.92 in. / 101.3 mB

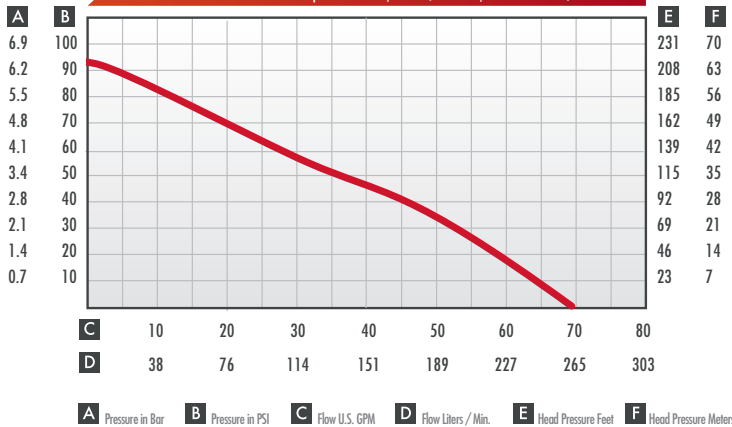

**ULTRA LIGHTWEIGHT, MULTI-POSITION  
HIGH PERFORMANCE FIRE PUMP**

- The WICK® 100-4M is powered by a reliable multi-position 4 stroke Honda GX50 engine. Ideal for operating at any angle and for backpack carrying.
- Comes mounted on a backboard style carrying base with cutout handle. Carrying straps optional
- Integral fuel tank
- Unique clutch feature for easy starting and water conservation
- The pump is a detachable, single-stage foam-compatible design for easy maintenance
- Available with a vertical mount discharge and also available with a base mounted hand primer
- Meets the emission standards of US EPA/ CARB regulations

**WEIGHT & DIMENSIONS**

Length	14.0"	36 cm
Width	11.0"	28 cm
Height	11.75"	30 cm
Weight	17.5 lbs	7.9 kg
Suction	1.5" NPSH	38 mm
Discharge	1.5" NPSH	38 mm

**ENGINE**

Honda GX50	4 stroke; 48 cc; 2.0* gros Hp @ 7000 RPM	
Clutch Drive		
Fuel Tank Capacity	0.67 Qt. US	0.63 L
Oil Capacity	.14 Qt US	0.13 L

\* Mass production engines may vary from this value.  
Specifications subject to change without notice

# FIRE PUMPS ULTRA LIGHTWEIGHT

17-20 LBS / 8-9 KG

## ULTRA LIGHTWEIGHT, HIGH PERFORMANCE FIRE PUMP

- For Emergency Rescue Equipment used by forestry and other emergency services
- Powered by a Mitsubishi MEIKI 2-Stroke 47cc engine
- All position .. will operate on any slope
- Unique clutch feature
- Detachable (bolt-on) foam-compatible single-stage pump end
- Integral fuel tank provides approximately 60 minutes run time
- Fuel tank protection guard
- Remote fuel (RFT) model significantly extends operational time
- 40% lower carbon emissions than our previous models
- 25% reduction in fuel consumption
- Optional electronic over-speed protection cut-out switch
- Frame bumper pads standard
- Optional transportable back pack



## WICK® 100M

	Part Number	Description
A	71WICK100M	WICK 100M (Without Remote fuel Option)
B	71WICK100M-RFT	WICK 100M Remote Fuel Kit Mercury model
B	71WICK100M-RFTCO	WICK 100M Remote Fuel Kit Mercury model, with electronic cut-out switch
C	71WICK100M-RFTCOP	WICK 100M Remote Fuel Kit Mercury model, with hand primer & electronic cut-out switch

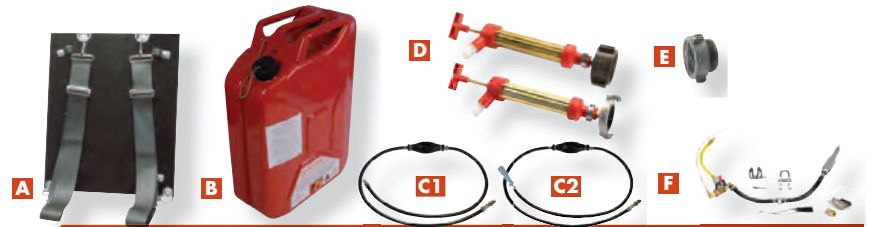

## OPTIONAL

	Part#	Description
A	71W25-HPACK	Back board for carrying
B	70FLPFT5B-USDAN	Metal Fuel Tank (USDA model) 25 Liters / 6.6 US Gal.
C1	70FLPFL-USDA	USDA pump fuel line
C2	70FLPFL-MU	Pump fuel line, USDA Male, Mercury Female
D	70FLHPPQC	Hand Primer 1 1/2" / 38mm QC
D	70FLHPPPS	Hand Primer 1 1/2" / 38mm NPSH
E	70FL15TPPS	Thread protector
F	71W11-RFTKIT-M	Remote fuel kit for WICK 100M fire pump

See website for complete listing of accessory and related products

## WEIGHT & DIMENSIONS

Length	13.5"	34 cm
Width	11.5"	29 cm
Height	12.0"	30.5 cm
Weight*	18.6	8.4 kg
Suction	1.5" NPSH	38 mm
Discharge	1.5" NPSH	38 mm

## ENGINE

Mitsubishi	Model TLE48	2 stroke; 47cc,
2.4 HP / 1.8 Kw		
Ignition	Electronic	
Clutch Drive		
Fuel Tank Capacity	0.89 Qt US	0.84 L

\* Weight shown for standard model. RFT model is 19.9 lbs / 9.0 kg

Specifications subject to change without notice

Performance standard correction as per SAE J1349; 60° F / 15.5° C; Baro 29.92 in. / 101.3 mB

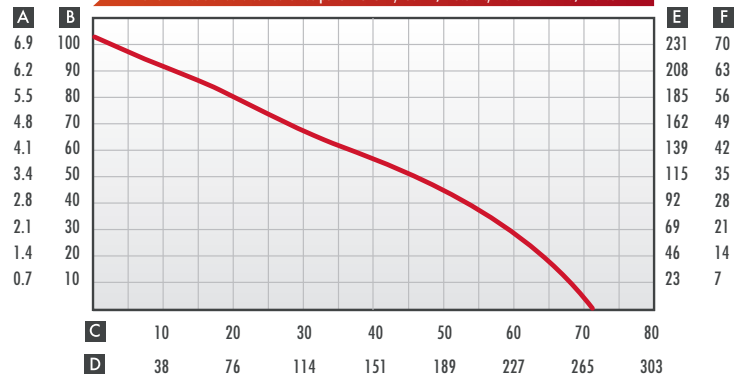

A Pressure in Bar B Pressure in PSI C Flow U.S. GPM D Flow Liters / Min. E Head Pressure Feet F Head Pressure Meters

W100M / 11/14/20



**WICK® 250**

Part#	Description
71WICK250-AC	WICK® 250 Fire Pump - Chrysler connection (New N-Coil)
71WICK250-MAC	WICK® 250 Fire Pump - Mercury connection (New N-Coil)
71WICK250-MAQC	WICK® 250 Fire Pump - Mercury connection (New N-Coil and low tone muffler)
71WICK250-SAEAC	WICK® 250 Fire Pump - SAE connection - c/w Spark Arrestor (New N-Coil)

**PORTABLE THREE STAGE  
HIGH PRESSURE FIRE PUMP**

- For Emergency Rescue Equipment used by forestry and other emergency services
- Light-weight, very stable, economical and high performance are the hallmarks of the WICK® 250
- Best performance of all fire pumps in its class
- 8 HP, 2-stroke engine coupled to a three-stage foam-compatible pump
- Electronic over-speed protection cut-out switch
- See chart for available fuel connection models
- Overall design for exceptional ease in maintenance
- Optional U.S.D.A. (United States Department of Agriculture) approved spark arrestor



**OPTIONAL**

	Part#	Description
A	71W25-HPACK	Back board for carrying
B	70FLPFT5	Fuel Tank .. 25 Liters / 6.6 US Gal. (see fuel section for complete listing)
C	70FLPFL	Chrysler fuel line
	70FLPFL-M	Mercury fuel line
	70FLPFL-NB	Fuel Line Complete with SAE swivel Female at both ends .. extended length
D	70FLHPPQC	Hand Primer 1 1/2" / 38mm QC
	70FLHPPPS	Hand Primer 1 1/2" / 38mm NPSH
E	71W37-SPKARR	WICK 250 Spark Arrestor
	F	70FL15TPPS
		70FL20TPPS

See website for complete listing of accessory and related products

**WEIGHT & DIMENSIONS**

Length	15.3"	39 cm
Width	13.0"	33 cm
Height	12.5"	31.8 cm
Weight	31 lbs	14.1 kg
Suction	2.0" NPSH	50 mm
Discharge	1.5" NPSH	38 mm

**ENGINE**

Hydro-Wick series	2 stroke; 134 cc ; 8.0 Hp @ 8000 RPM
Cylinder	Nikasil
Ignition	Flywheel magneto / solid state breaker less

Specifications subject to change without notice

Performance standard correction as per SAE J1349; 60° F / 15.5° C; Baro 29.92 in. / 101.3 mB

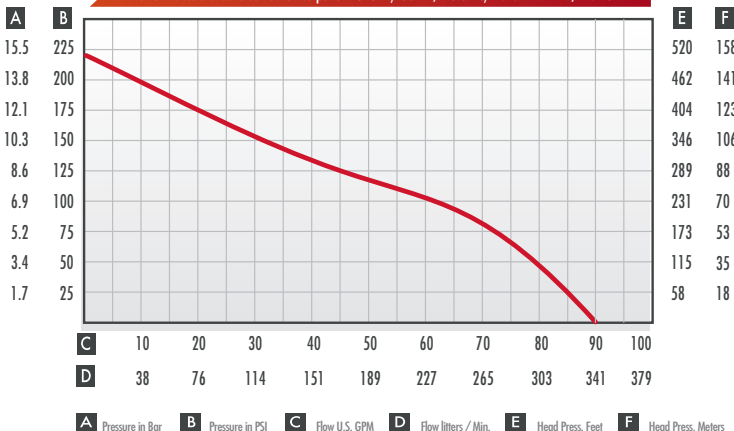



## WICK® 375

### PORTABLE FOUR STAGE HIGH PRESSURE FIRE PUMP

- For Emergency Rescue Equipment used by forestry and other emergency services
- The WICK® 375 is a world leader in portable high pressure fire pumps capable of moving water over long distances
- Powered by a 10 HP, 210 cc modern 2-stroke Solo engine
- Electronic over-speed protection cut-out switch
- Detachable 4-stage foam-compatible pump end using a one piece stainless steel clamp
- Nikasil cylinder wall for extended wear and low maintenance
- User friendly and easy pull starting
- Detachable rewind starter for emergency rope start
- See chart for available fuel connection models
- Meets U.S.D.A. specification 5100-27 4E

Part#	Description
71WICK375-A	WICK® 375 Fire Pump - Mercury fuel connection
71WICK375-C	WICK® 375 Fire Pump - Chrysler fuel connection
71WICK375-SAE	WICK® 375 Fire Pump - SEA fuel connection
71WICK375-Y	WICK® 375 Fire Pump - Yamaha fuel connection
71WICK375-YNZ	WICK® 375 Fire Pump - Yamaha fuel connection for New Zealand, incl Heat Shield & Spark arrestor
71WICK375-USDA	WICK® 375 Fire Pump - USDA
71WICK375-ASWD	WICK® 375 Fire Pump - Mercury fuel connection / Special Sweden



### OPTIONAL

	Part#	Description
A	71W37-HPACK	Back board for carrying
B	70FLPFT5	Fuel Tank .. 25 Liters / 6.6 US Gal. (see fuel section for complete listing)
C1	70FLPFL-M	Fuel Line Complete (Mercury)
C2	70FLPFL	Fuel Line Complete (Chrysler)
C3	70FLPFL-Y	Fuel Line Complete (Yamaha)
C4	70FLPFL-MAN	Fuel Line Complete Mercury Female (Manitoba)
C5	70FLPFL-GSA	Fuel Line Complete with SAE swivel Female at both ends
C5	70FLPFL-NB	Fuel Line Complete with SAE swivel Female at both ends .. extended length
C6	70FLPFL-USDA	Fuel Line Complete (USDA)
D	70FLHPPPS	Hand Primer 1 1/2" / 38mm NPSH (see website for other threads and sizes)
D	70FLHPPQC	Hand Primer 1 1/2" / 38mm QC
E	71W37-SPKARR	Spark Arrestor (WICK 250 and WICK 375)
F	70FL15TPPS	Thread protector 1 1/2" / 38mm
F	70FL20TPPS	Thread protector 2" / 51mm
G	71W37-1327	Heat Shield

See website for complete listing of accessory and related products

### WEIGHT & DIMENSIONS

Length	22.75"	57.8 cm
Width	14.25"	36.2 cm
Height	14.25"	36.2 cm
Weight	56.0 lbs	25.4 kg
Suction	2.0" NPSH	50 mm
Discharge	1.5" NPSH	38 mm

### ENGINE

Solo	2 stroke; 210 cc; 10.0 Hp
Ignition	Flywheel magneto; solid state; breaker less
Cylinder	Nikasil cylinder wall
Lighting coil	20 Watts

Specifications subject to change without notice

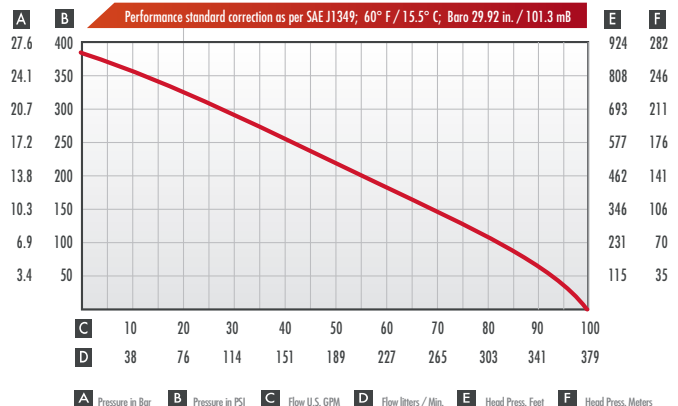



**WICK® 200**

Part#	Description
71WICKF201-10S-A	WICK® 200 Fire Pump - Mercury fuel connection
71WICKF201-10S-C	WICK® 200 Fire Pump - Chrysler fuel connection
71WICKF201-10S-ASW	WICK® 200 Fire Pump - Mercury fuel connection / Special Sweden
71WICKF201-10S-CJP	WICK® 200 Fire Pump - Chrysler fuel connection / Special Japan

**PORTABLE TWO STAGE HIGH VOLUME FIRE PUMP**

- For Emergency Rescue Equipment used by forestry and other emergency services
- The WICK® 200 is the culmination of modern pump and engine design resulting in unsurpassed performance
- Powered by a 10 HP, 210 cc modern 2-stroke Solo engine
- Electronic over-speed protection cut-out switch
- Detachable 2-stage foam-compatible pump using a one piece stainless steel clamp
- Nikasil cylinder wall for extended wear and low maintenance
- User friendly and easy pull starting
- Detachable rewind starter for emergency rope start
- See chart for available fuel connection models



**OPTIONAL**

	Part#	Description
A	71W37-HPACK	Back board for carrying
B	70FLPFT5	Fuel Tank .. 25 Liters / 6.6 US Gal. (see fuel section for complete listing)
C1	70FLPFL-M	Fuel Line Complete (Mercury)
C2	70FLPFL	Fuel Line Complete (Chrysler)
C3	70FLPFL-Y	Fuel Line Complete (Yamaha)
C4	70FLPFL-MAN	Fuel Line Complete Mercury Female (Manitoba)
C5	70FLPFL-GSA	Fuel Line Complete with SAE swivel Female at both ends
C5	70FLPFL-NB	Fuel Line Complete with SAE swivel Female at both ends .. extended length
C6	70FLPFL-USDA	Fuel Line Complete (USDA)
D	70FLHPPPS	Hand Primer 1 1/2" / 38mm NPSH (see website for other threads and sizes)
D	70FLHPPQC	Hand Primer 1 1/2" / 38mm QC
E	71W37-SPKARR	Spark Arrestor (WICK 250 and WICK 375)
F	70FL15TPPS	Thread protector 1 1/2" / 38mm
F	70FL20TPPS	Thread protector 2" / 51mm
G	71W37-1327	Heat Shield

See website for complete listing of accessory and related products

**WEIGHT & DIMENSIONS**

Length	22.75"	57.8 cm
Width	14.25"	36.2 cm
Height	14.25"	36.2 cm
Weight	51.75 lbs	23.8 kg
Suction	2.0" NPSH	50 mm
Discharge	1.5" NPSH	38 mm

**ENGINE**

Solo	2 stroke; 210 cc; 10.0 Hp
Ignition	Flywheel magneto; solid state; breaker less
Cylinder	Nikasil cylinder wall
Lighting coil	20 Watts

Specifications subject to change without notice

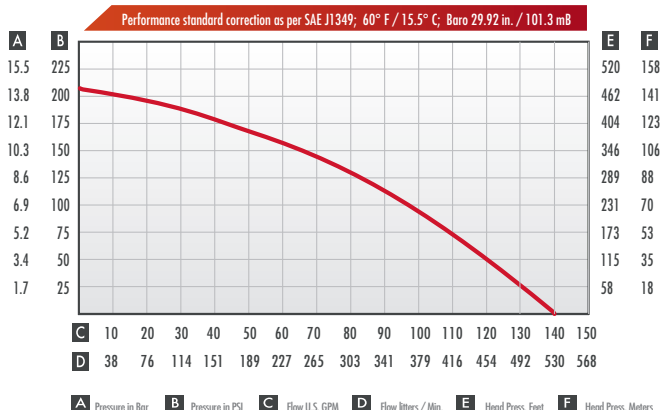

## PORTABLE THREE STAGE HIGH PRESSURE FIRE PUMP

- Powered by a 4 stroke, air cooled Kohler Command Pro®\* 7 HP overhead cam engine with over-speed protection and low level oil sensor
- One of the quietest engines in its class
- Automatic decompression system for easy one pull starting
- Quad-clean™\*\* all season four stage cyclonic air cleaner
- Forged steel crankshaft with dual ball bearings
- Up to 15% lighter than the competition
- Produces 43 to 65% greater pressure
- Flows 25 to 30% more water at 100psi (6.9 Bar)
- Can work in tandem at more than 400psi (28 Bar)
- 3 Year manufacturer's warranty on the engine
- Three stage foam compatible pump end
- Anodized aluminum impellers and distributors
- Maintenance-free speed increaser
- Available frames
  - Base for vehicle mount, with carrying handle for easy transportation.
  - Also available with wraparound tubular frame.
  - Both frames include rubber anti-slip mounts
- Optional electric start model
- Pump end and speed increaser can be rotated to multiple positions
- One of the most fuel efficient engines on the market using a belt box/pump end combination

### WEIGHT & DIMENSIONS\*

Length	19.0"	48.3 cm
Width	15.0"	40.6 cm
Height	19.0"	48.3 cm
Weight (Dry)**	53.0 lbs	24.1 kg
Suction	2.0"	50 mm NPSH
Discharge	1 1/2"	38 mm NPSH

### ENGINE

Kohler Command Pro®	Four Stroke
Power	7 HP gross @ 4000 RPM
Ignition	Electronic breakerless
Fuel Tank Capacity	0.95 US Gallons 3.6 litres

\* Quad-clean™ and Command Pro® are trade marks of Kohler

\*\* Add 6.0 lbs / 2.7Kg for electric start model

Specifications subject to change without notice

Optional Carrying handles



## WICK® SI 250

	Part#	Description
A	71WICKSI251-7K	7 HP 4 Stroke Kohler, 3 stage pump end, integral fuel tank and base for vehicle mount
B	71WICKSI251-7KE	7 HP 4 Stroke Kohler, Electric start, 3 stage pump end, integral fuel tank and base for vehicle mount
A	71WICKSI251-7KTR	7 HP 4 Stroke Kohler, 3 stage pump end, integral fuel tank and c/w wraparound frame
A	71WICKSI251-7KETR	7 HP 4 Stroke Kohler, Electric start, 3 stage pump end, integral fuel tank and c/w wraparound frame
B	71WICKSI251-7KEH	7 HP 4 Stroke Kohler, Electric start, 3 stage pump end, integral fuel tank, horizontal speed increaser and base for vehicle mount

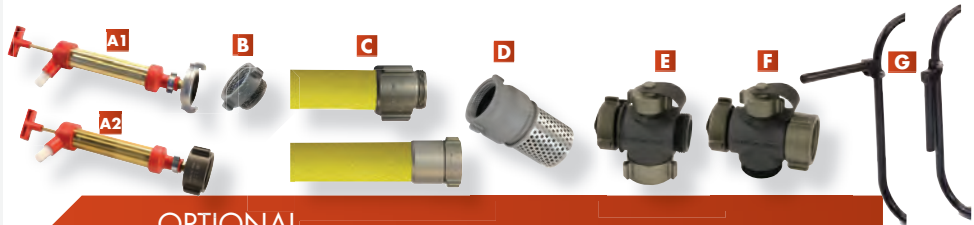

### OPTIONAL

	Part#	Description
A1	70FLHPPQC	Hand Primer QC
A2	70FLHPPPS	Hand Primer NPSH
A2	70FLHPPNH	Hand Primer NH
B	70FL15TPPS	Thread protector 1 1/2" / 38mm
B	70FL20TPPS	Thread protector 2" / 51mm
B	6124NM24PF	Adaptor .. 1 1/2" / 38mm NH Male x 1 1/2" / 38mm NPSH Female
C	70FL20DLPST0	Draftlite HP suction hose .. 2"/51mm x 10'/3M c/w NPSH *
D	70FLV2PF	Foot Valve / Strainer 2"/51mm NPSH Female *
E	70FLM15PF2NM10PM-A	Manifold 1 1/2"/38mm NH Male x 1 1/2"/38mm NPSH Swivel Female x 1 1/2"/38mm NH Male with 1"/25mm NPSH side port .. c/w caps **
F	70FLM15PF2NM10PM-B	Manifold 1 1/2"/38mm NH Male x 1 1/2"/38mm NH Male x 1 1/2"/38mm NPSH Swivel Female with 1"/25mm NPSH side port .. c/w caps **
G	71W07-HKIT	Folding handles kit for tubular frame

\* See website for complete listing of accessory and related products

\*\* Call for thread variations

Performance standard correction as per SAE J1349; 60° F / 15.5° C; Baro 29.92 in. / 101.3 mB





**WICK® si 250H**

	Part#	Description
A	71WICKSI251-7	6.5 (5.8 net) HP 4 Stroke Honda , Electric start, 3 stage pump end, integral fuel tank and base for vehicle mount
A	71WICKSI251-7HEH	6.5 (5.8 net) HP 4 Stroke Honda , Electric start, 3 stage pump end, integral fuel tank, horizontal speed increaser and base for vehicle mount
B	71WICKSI251-7HETR	6.5 (5.8 net) HP 4 Stroke Honda , Electric start, 3 stage pump end, integral fuel tank and c/w wraparound frame. Optional folding handles

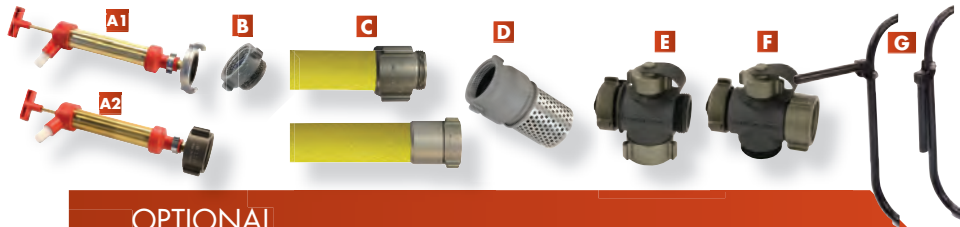

**OPTIONAL**

	Part#	Description
A1	70FLHPPQC	Hand Primer QC
A2	70FLHPPPS	Hand Primer NPSH
A2	70FLHPPNH	Hand Primer NH
B	70FL15TPPS	Thread protector 1 1/2" / 38mm
B	70FL20TPPS	Thread protector 2" / 51mm
B	6124NM24PF	Adaptor .. 1 1/2" / 38mm NH Male x 1 1/2" / 38mm NPSH Female
C	70FL20DLPST0	Draftlite HP suction hose .. 2"/51mm x 10'/3M c/w NPSH *
D	70FLFV2PF	Foot Valve / Strainer 2"/51mm NPSH Female *
E	70FLM15PF2NM10PM-A	Manifold 1 1/2"/38mm NH Male x 1 1/2"/38mm NPSH Swivel Female x 1 1/2"/38mm NH Male with 1"/25mm NPSH side port .. c/w caps **
F	70FLM15PF2NM10PM-B	Manifold 1 1/2"/38mm NH Male x 1 1/2"/38mm NH Male x 1 1/2"/38mm NPSH Swivel Female with 1"/25mm NPSH side port .. c/w caps **
G	71W07-HKIT	Folding handles kit for tubular frame

\* See website for complete listing of accessory and related products  
\*\* Call for thread variations

**PORTABLE THREE STAGE  
HIGH PRESSURE FIRE PUMP**

- Powered by a 4 stroke, air cooled Honda 6.5 (5.8 net) HP overhead cam engine with over-speed protection and low level oil sensor
- One of the quietest engines in its class
- Automatic decompression system for easy one pull starting
- All season dual stage air cleaner
- Forged steel crankshaft with dual ball bearings
- Up to 15% lighter than the competition
- Produces 43 to 65% greater pressure
- Flows 25 to 30% more water at 100psi (6.9 Bar)
- Can work in tandem at more than 400psi (28 Bar)
- 3 Year manufacturer's warranty on the engine
- Three stage foam compatible pump end
- Anodized aluminum impellers and distributors
- Maintenance-free speed increaser
- Standard base for vehicle mount, with carrying handle for easy transportation. Also available with wraparound tubular frame. Both frames include rubber anti-slip mounts
- Pump end and speed increaser can be rotated to multiple positions
- One of the most fuel efficient engines on the market using a belt box/pump end combination
- Electric start (battery not included)

**WEIGHT & DIMENSIONS\***

Length	19.0"	48.3 cm
Width	17.4"	44.2 cm
Height	19.0"	48.3 cm
Weight (Dry)	54.0 lbs	24.5 kg
Suction	2.0"	50 mm NPSH
Discharge	1 1/2"	38 mm NPSH

**ENGINE**

Honda	196 cc Four Stroke
Power	5.8 net HP @ 3600 RPM
Ignition	Electronic breakerless
Fuel Tank Capacity	0.82 US Gallons      3.1 litres

Specifications subject to change without notice

Performance standard correction as per SAE J1349; 60° F / 15.5° C; Baro 29.92 in. / 101.3 mB

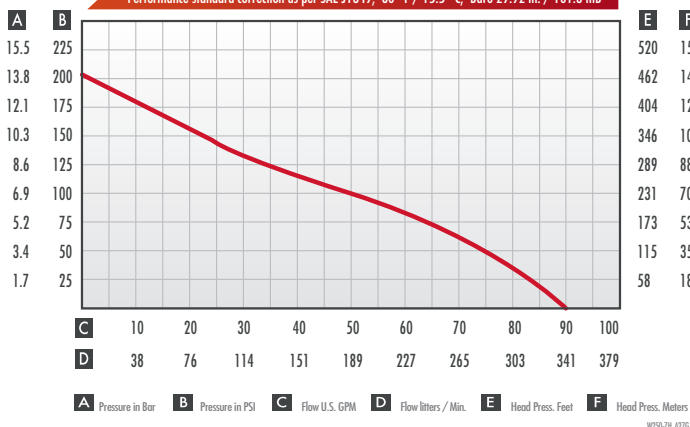

# FIRE PUMPS LIGHTWEIGHT PORTABLE

30-55 LBS / 14-25 KG

## PORTABLE THREE STAGE HIGH PRESSURE FIRE PUMP

- Highest pressure performance in its category
- Exceeds Federal pump performance requirements for Type 7 apparatus
- Powered by a 4 stroke, air cooled Briggs & Stratton Vanguard™ 10 HP overhead valve engine with over-speed protection.
- Super easy starting
- Most fuel efficient engine meeting type 7 requirements
- Overhead valve design allows for cooler and cleaner runs, delivering more power, longer engine life, improved fuel economy and lower emissions
- Racing designed connecting rod and head gasket for increased torque and improved oil flow through the engine maximizing internal component protection
- Forged crankshaft incorporating heat treated ball bearings to minimize friction and heat build-up
- Equipped with TransportGuard™ system\* which provides a simultaneous fuel/ignition shut-off to protect the engine from oil/fuel dilution during transport
- Available with fuel line (less integral tank), for remote fuel tank operation
- **Value protection model** comes standard with remote fuel connection, low pressure shut-off and other standard features. See website for details.
- Acoustically designed muffler for improved tonal quality and lowered noise level
- High capacity commercial air cleaner
- Can work in tandem at more than 400psi (28 Bar)
- Three stage foam compatible pump end
- Pump end and speed increaser can be rotated to multiple positions
- Anodized aluminum impellers and distributors
- Maintenance-free speed increaser
- Available with wraparound frame and carrying handles
- 3 year manufacturer's warranty on the engine
- Standard electric start motor (battery not included)

### WEIGHT & DIMENSIONS

Length	22.0"	55.9 cm
Width	18.75"	47.6 cm
Height	18.25"	46.4 cm
Weight (Dry) **	78.0 lbs.	35.4 kg
Suction	2.0"	50 mm NPSH
Discharge	1 1/2"	38 mm NPSH

### ENGINE

Briggs & Stratton Vanguard™	Four Stroke
Power	10 HP gross @ 3600 RPM
Ignition	Magnetron electric ignition
Fuel Tank Capacity	0.95 US Gallons 3.6 liters
Oil Capacity	28 Ounces 0.8 Liters

\* When ordered with integral fuel tank only  
TransportGuard™ is a trade mark of Briggs & Stratton

\*\* Unit weight 82 lbs. (37.2 KG) with channel base and 87 lbs. (39.5 KG) with carry frame

Specifications subject to change without notice



**WICK® SI 300**

	Part#	Description
A	71WICKSI301-10BTC	WICK Si 300-10B .. Tubular carrying frame, integrated fuel tank
B	71WICKSI301-10VP-M	WICK Si 300-10B .. Value Protection model with loss of prime shutdown
B	71WICKSI301-10BTRL	WICK Si 300-10B .. Wraparound frame, less fuel tank (handles optional)
B	71WICKSI301-10BSWE	Wraparound frame, less fuel tank, (handles standard) c/w Mercury fuel connection
C	71WICKSI301-10BC	WICK Si 300-10B .. Channel frame .. for truck mount, integrated fuel tank
D	71WICKSI301-10BTR	WICK Si 300-10B .. Wraparound frame, integrated fuel tank (handles optional)
N/1	71WICKSI301-10B	WICK Si 300-10B .. Less frame, integrated fuel tank
N/1	71WICKSI301-10BTCL	WICK Si 300-10B .. Tubular carrying frame, less fuel tank
N/1	71WICKSI301-10BCL	WICK Si 300-10B .. Channel frame, less fuel tank
N/1	71WICKSI301-10BL	WICK Si 300-10B .. Less frame and less fuel tank

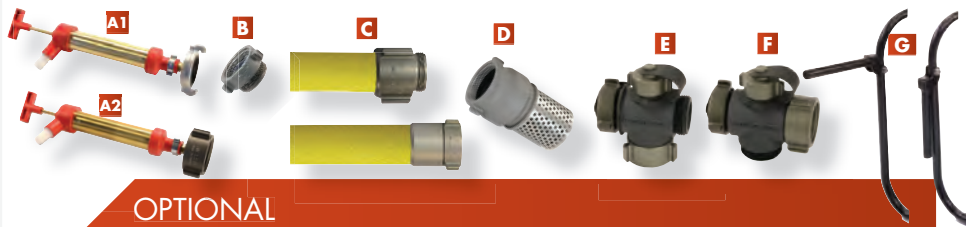

### OPTIONAL

	Part#	Description
A1	70FLHPPQC	Hand Primer QC
A2	70FLHPPPS	Hand Primer NPSH
A2	70FLHPPNH	Hand Primer NH
B	70FL1STPPS	Thread protector 1 1/2" / 38mm
B	70FL20TPPS	Thread protector 2" / 51mm
B	6124NM24PF	Adaptor .. 1 1/2" / 38mm NH Male x 1 1/2" / 38mm NPSH Female
C	70FL20DLPS10	Drafflite HP suction hose .. 2" / 51mm x 10' / 3M c/w NPSH *
D	70FLFV2PF	Foot Valve / Strainer 2" / 51mm NPSH Female *
E	70FLM15PF2NM10PM-A	Manifold 1 1/2" / 38mm NH Male x 1 1/2" / 38mm NPSH Swivel Female x 1 1/2" / 38mm NH Male with 1" / 25mm NPSH side port .. c/w caps **
F	70FLM15PF2NM10PM-B	Manifold 1 1/2" / 38mm NH Male x 1 1/2" / 38mm NH Male x 1 1/2" / 38mm NPSH Swivel Female with 1" / 25mm NPSH side port .. c/w caps **
G	71W30-HKIT	Folding handles kit for tubular frame

\* See website for complete listing of accessory and related products  
\*\* Call for thread variations

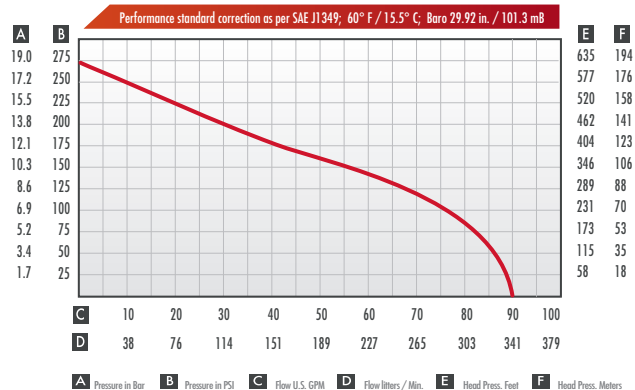



## WICK XP2-13

	Part#	Description
A	71WICKF200-13HT	WICK® XP2-13 Pumper ..13 HP 4 Stroke Honda , 2 stage pump, tubular frame for easy transportation
B	71WICKF200-13HCH	WICK® XP2-13 Pumper ..13 HP 4 Stroke Honda , 2 stage pump, Horizontal Speed increaser model with channel frame
N/I	71WICKF200-13HC	WICK® XP2-13 Pumper ..13 HP 4 Stroke Honda , 2 stage pump, Vertical Spee increaser, Channel frame model for vehicle mount
N/I	71WICKF200-13HTH	WICK® XP2-13 Pumper ..13 HP 4 Stroke Honda , 2 stage pump, Horizontal Speed increaser model with tubular frame

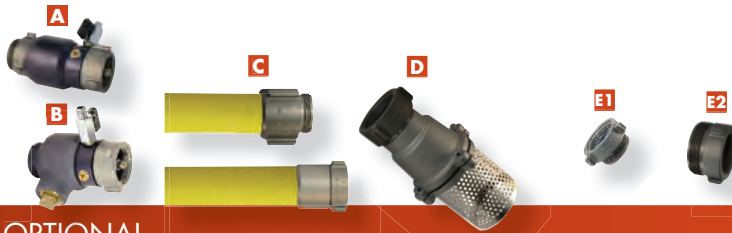

### OPTIONAL

	Part#	Description
A	70FL15CVPXX	Poppet Check Valve *
B	70FL15CVPSPXX	Primer / Poppet Check Valve with 1" / 25mm NPT Side port *
C	70FL20DLPST0	Draftlite HP suction hose .. 2" / 51mm x 10' / 3M c/w NPSH *
D	70FLV2PF	Foot Valve / Strainer 2" / 51mm NPSH Female *
E1	70FL15TPPS	Thread protector 1 1/2" / 38mm
E2	70FL20TPPS	Thread protector 2" / 51mm

\* See website for complete listing of accessory and related products

### PORTABLE TWO STAGE HIGH PRESSURE FIRE PUMP

- Powered by a 4 stroke, air cooled Honda engine with over-speed protection
- Electric start (battery optional) with manual recoil backup
- Automotive style air cleaner and external oil filter
- Two stage foam compatible pump end, interchangeable with our 2 stage pumps and with our F4200 four stage pump end for increased pressure
- Engine and pump are coupled with our stainless steel quick release clamp
- Maintenance-free speed increaser
- Standard discharge gauge and adaptor
- Choice of hand carrying tube frame or a channel base frame for vehicle mount
- Hand priming pump and pressure gauge included
- Optional non-return discharge valve

### WEIGHT & DIMENSIONS

Length	33.0"	84 cm
Width	19.5"	50 cm
Height	18.5"	47 cm
Weight	117 lbs	53 kg
Suction	2.0" NPSH	50 mm
Discharge	1.5" NPSH	38 mm

### ENGINE

Honda GX390	4 stroke; 13* gross Hp @ 3600 RPM
Oil filter	Cartridge-type spin-on filter
Fuel Tank Capacity	1.7 US Gal.      6.5 L
Electronic Ignition	

\* Net power output is 11.7 Hp @ 3600 RPM  
Specifications subject to change without notice

Performance standard correction as per SAE J1349; 60° F / 15.5° C; Baro 29.92 in. / 101.3 mB

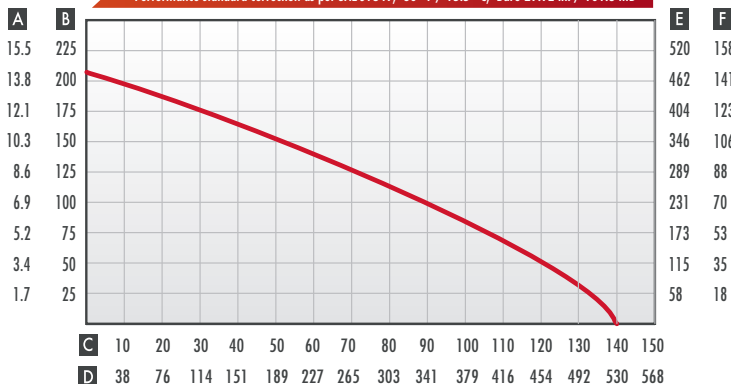

A Pressure in Bar    B Pressure in PSI    C Flow U.S. GPM    D Flow liters / Min.    E Head Press. Feet    F Head Press. Meters  
P200-13H / C02L / 3H

# FIRE PUMPS PORTABLE

115-135 LBS / 53-62 KG

## PORTABLE THREE STAGE HIGH PRESSURE FIRE PUMP

- Ideal for wildland applications requiring high pressure and volumes over mountainous terrain
- Powered by a 4 stroke, air cooled Honda 13 HP\* engine with over-speed protection
- The engine meets EPA and CARB emission standards
- Electric start (battery optional) with manual recoil backup
- Automotive style air cleaner and external oil filter
- Three stage foam compatible pump end, interchangeable with our 2 stage pump end for increased flow and with our 4 stage pump end for increased pressure.
- Engine and pump are coupled with our stainless steel quick release clamp
- Maintenance-free speed increaser
- Pump standard with sealed bearing
- Standard 600 psi discharge gauge
- Choice of hand carrying frame, semi wraparound tube frame or channel base frame for vehicle mount
- Hand priming pump (brass cylinder)

### WEIGHT & DIMENSIONS

Length	34.25"	87.0 cm
Width***	22.5"	57.2 cm
Height	20.5"	52.1 cm
Weight (Dry) **	128.5 lbs	58.4 kg
Suction	2.0" NPSH	50 mm
Discharge	1.5" NPSH	38 mm

\*\* Weight & Dimensions are for model shown above (71WK3200-13HTC)

\*\*\* Width includes muffler shield (21.25" / 54 cm without shield)

### ENGINE

Honda GX390	4 stroke	13HP @3600 RPM*
Oil filter	Cartridge-type spin-on filter	
Fuel Tank Capacity	1.7 US Gal. / 6.5 L	
Electronic Ignition		

\*Net power output is 11.7 Hp @ 3600 RPM.

Mass production engines may vary from this value.

Specifications subject to change without notice

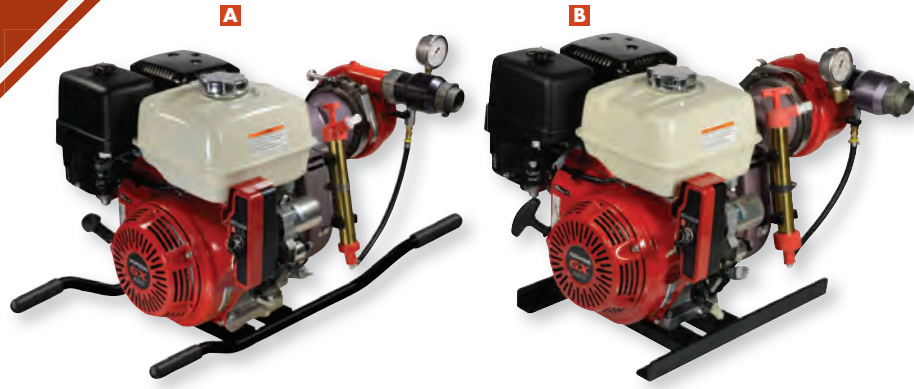

## WICK XP3-13

	Part Number	Description
A	71WK3200-13HTC	WICK XP3-13 Pumper ..13 HP 4 Stroke Honda , 3 stage pump, twin handle frame model
A	71WK3200-13HTCH	WICK XP3-13 Pumper ..13 HP 4 Stroke Honda , 3 stage pump, twin handle frame model, horizontal speed increaser
B	71WK3200-13HCH	WICK XP3-13 Pumper ..13 HP 4 Stroke Honda , 3 stage pump, Channel frame model for vehicle mount, horizontal speed increaser
B	71WK3200-13HCH-DR	WICK XP3-13 Pumper ..13 HP 4 Stroke Honda , 3 stage pump, Channel frame model for vehicle mount with drain, horizontal speed increaser

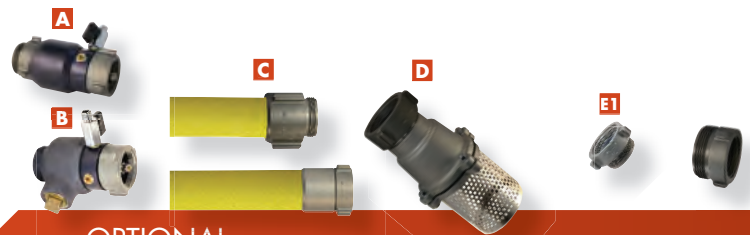

### OPTIONAL

	Part#	Description
A	70FL15CVPXX	Poppet Check Valve *
B	70FL15CVPSPXX	Primer / Poppet Check Valve with 1" / 25mm NPT Side port *
C	70FL20DLP510	Draftlite HP suction hose .. 2" / 51mm x 10' / 3M c/w NPSH *
D	70FLFV2PF	Foot Valve / Strainer 2" / 51mm NPSH Female *
E1	70FL15TPPS	Thread protector 1 1/2" / 38mm
E2	70FL20TPPS	Thread protector 2" / 51mm

\* See website for complete listing of accessory and related products

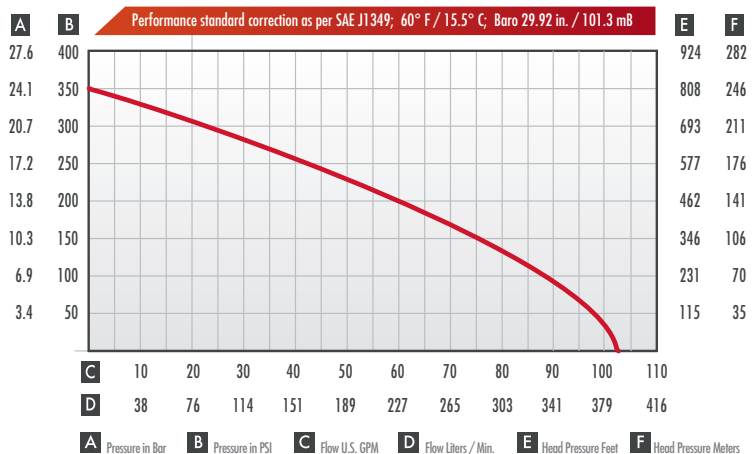

W2200-13H / S19G/3H



# WICK XP4-13

	Part#	Description
A	71WK4203-13HC	WICK® XP4-13 Pumper ..13 HP 4 Stroke Honda , 4 stage pump, Channel frame model for vehicle mount
B	71WK4203-13HT	WICK® XP4-13 Pumper ..13 HP 4 Stroke Honda , 4 stage pump, semi wrap around frame for easy transportation
A	71WK4203-13HCH	WICK® XP4-13 Pumper ..13 HP 4 Stroke Honda , 4 stage pump, Horizontal Speed increaser model with channel frame
B	71WK4203-13HTH	WICK® XP4-13 Pumper ..13 HP 4 Stroke Honda , 4 stage pump, Horizontal Speed increaser, semi wrap around frame for easy transportation

## PORTABLE FOUR STAGE HIGH PRESSURE FIRE PUMP

- Powered by a 4 stroke, air cooled Honda engine with over-speed protection
- Electric start (battery optional) with manual recoil backup
- Automotive style air cleaner and external oil filter
- Four stage foam compatible pump end, interchangeable with our 4 stage pumps and with our F200 two stage pump end for increased volume
- Engine and pump are coupled with our stainless steel quick release clamp
- Maintenance-free speed increaser
- Standard discharge gauge and adaptor
- Choice of hand carrying tube frame or a channel base frame for vehicle mount
- Hand priming pump and pressure gauge included
- Optional non-return discharge valve

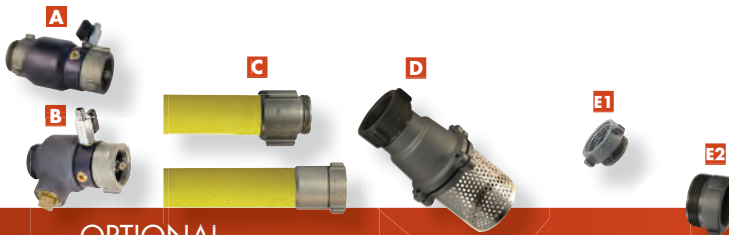

### OPTIONAL

	Part#	Description
A	70FL15CVPXX	Poppet Check Valve *
B	70FL15CVPSPXX	Primer / Poppet Check Valve with 1" / 25mm NPT Side port *
C	70FL20DLP510	Draftlite HP suction hose .. 2" / 51mm x 10' / 3M c/w NPSH *
D	70FLV2PF	Foot Valve / Strainer 2" / 51mm NPSH Female *
E1	70FL15TPPS	Thread protector 1 1/2" / 38mm
E2	70FL20TPPS	Thread protector 2" / 51mm

\* See website for complete listing of accessory and related products

### WEIGHT & DIMENSIONS

Length	33.0"	84 cm
Width	19.5"	50 cm
Height	18.5"	47 cm
Weight	123 lbs	56.7 kg
Suction	2.0" NPSH	50 mm
Discharge	1.5" NPSH	38 mm

### ENGINE

Honda GX390	4 stroke; 13* gross Hp @ 3600 RPM
Oil filter	Cartridge-type spin-on filter
Fuel Tank Capacity	1.7 US Gal.      6.5 L
Electronic Ignition	

\* Net power output is 11.7 Hp @ 3600 RPM  
Specifications subject to change without notice

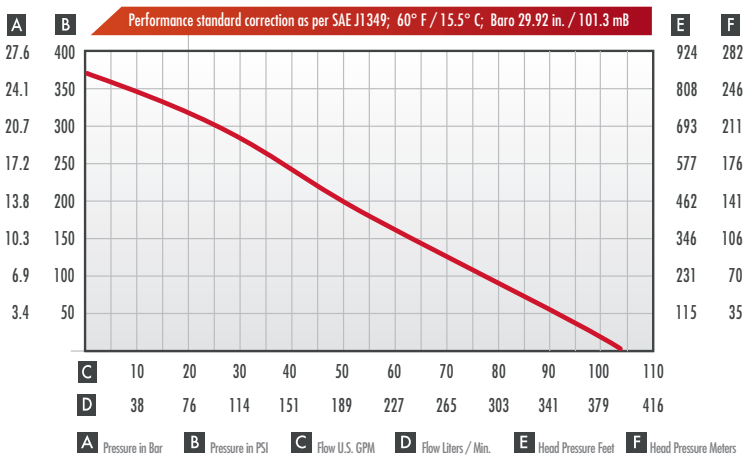

# FIRE PUMPS PORTABLE

115-135 LBS / 53-62 KG

## PORTABLE FOUR STAGE HIGH PRESSURE FIRE PUMP

- Powered by a 14 HP, 4 stroke, Briggs and Stratton Vanguard air cooled engine with over-speed protection
- Electric start (battery optional) with manual recoil backup
- Cyclonic air cleaner
- Standard High inclination engine which can work at up to 45 degree angle.
- Four stage foam compatible pump end, interchangeable with our 2 stage pump end for increased volume.
- Engine and pump are coupled with our stainless steel quick release clamp
- Maintenance-free speed increaser
- Choice of hand carrying tube frame or a channel base frame for vehicle mount
- Hand priming pump and pressure gauge included
- Optional Remote Fuel (RFT) connection
- **Our value protection model** comes standard with our low pressure shut-off and RFT connection for extended run time

### WEIGHT & DIMENSIONS

Length	33.0"	84 cm
Width	18.5"	47 cm
Height	19.0"	48 cm
Weight	131 lbs	59.4 kg
Suction	2.0" NPSH	50 mm
Discharge	1.5" NPSH	38 mm

### ENGINE

Briggs and Stratton	4 stroke; 14 Hp @ 3600 RPM
Oil filter	Cartridge-type spin-on filter
Ignition	Electronic
Integral tank	1.6 Gal US      6 liters

Specifications subject to change without notice

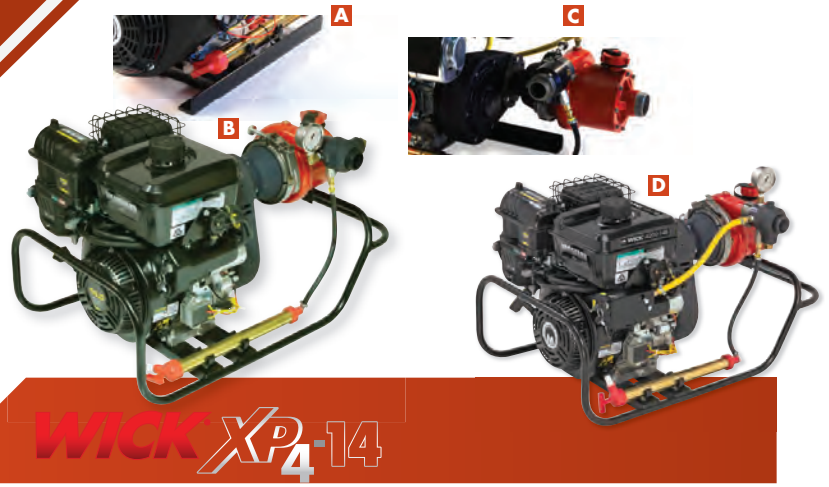

## WICK XP4-14

	Part#	Description
A	71WK4203-14BC	WICK® XP4-14 Pumper ..14 HP 4 Stroke Briggs & Stratton , 4 stage pump, Channel frame model for vehicle mount
B	71WK4203-14BT	WICK® XP4-14 Pumper ..14 HP 4 Stroke Briggs & Stratton , 4 stage pump, semi wrap around frame for easy transportation
C	71WK4203-14BCH	WICK® XP4-14 Pumper ..14 HP 4 Stroke Briggs & Stratton , 4 stage pump, Horizontal Speed increaser model with channel frame
D	71WK4203-14BTV	WICK® XP4-14 Pumper ..Value Protection model, 4 stage pump, standard with low pressure shut-off and remote fuel connection for extended run time.



### OPTIONAL

	Part#	Description
A	71W42-2715	Large control panel
B	71W42-2083	Exhaust Primer
C	70FLPFTXX	Fuel Tank .. see website for complete listing
D	70FLPFL-XX	Fuel line .. see website for complete listing
E	70FL15TPPS	Thread protector 1 1/2" / 38mm
E	70FL20TPPS	Thread protector 2" / 51mm
F	70FL20DLP10	Draftlite HP suction hose .. 2"/51mm x 10'/3M c/w NPSH *
G	70FLFV2PF	Foot Valve / Strainer 2"/51mm NPSH Female *

\* See website for complete listing of accessory and related products

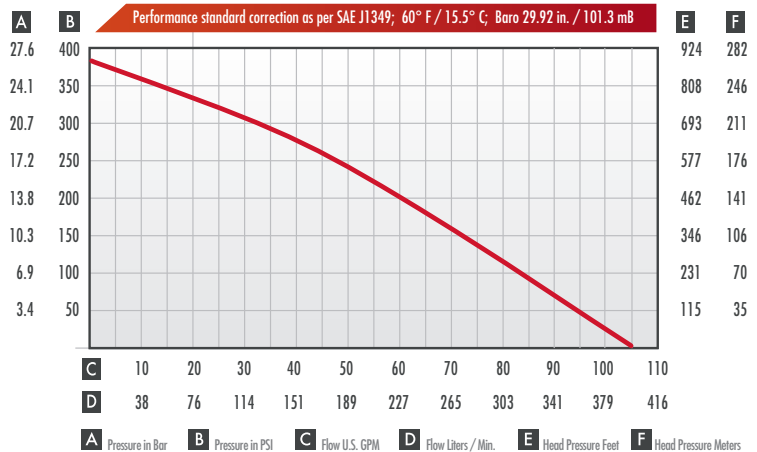



# WICK XP2-14

	Part#	Description
A	71WICKF200-14BC	WICK® XP2-14 Pumper ..14 HP 4 Stroke Briggs & Stratton , 2 stage pump, Channel frame model for vehicle mount
B	71WICKF200-14BT	WICK® XP2-14 Pumper ..14 HP 4 Stroke Briggs & Stratton , 2 stage pump, semi wrap around frame for easy transportation
C	71WICKF200-14BCH	WICK® XP2-14 Pumper ..14 HP 4 Stroke Briggs & Stratton , 2 stage pump, Horizontal Speed increaser model with channel frame
D	71WICKF200-14BTVP	WICK® XP2-14 Pumper ..Value Protection model, 2 stage pump, standard with low pressure shut-off and remote fuel connection for extended run time.



## OPTIONAL

	Part#	Description
A	71W42-2715	Large control panel
B	71W42-2083	Exhaust Primer
C	70FLPFTXX	Fuel Tank .. see website for complete listing
D	70FLPFL-XX	Fuel line .. see website for complete listing
E	70FL15TPPS	Thread protector 1 1/2" / 38mm
E	70FL20TPPS	Thread protector 2" / 51mm
F	70FL20DLP10	Draftlite HP suction hose .. 2"/51mm x 10'/3M c/w NPSH *
G	70FLV2PF	Foot Valve / Strainer 2"/51mm NPSH Female *

\* See website for complete listing of accessory and related products

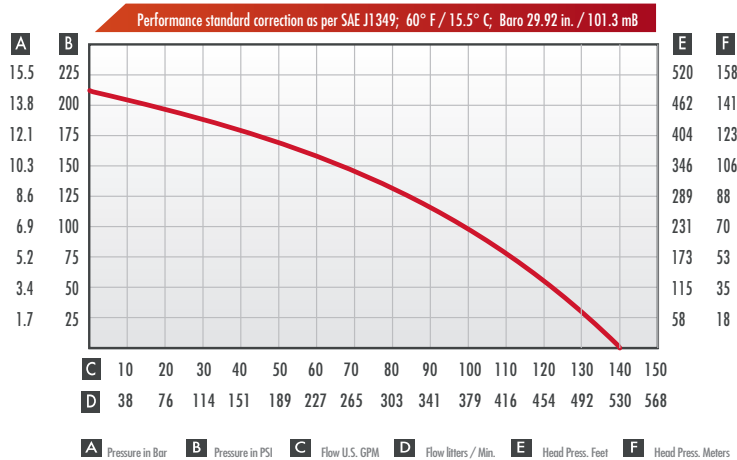

## PORTABLE TWO STAGE HIGH PRESSURE FIRE PUMP

- Powered by an 14 HP, 4 stroke, Briggs and Stratton Vanguard air cooled engine with over-speed protection
- Electric start (battery optional) with manual recoil backup
- Automotive style air cleaner and external oil filter
- Standard High inclination engine which can work at up to 45 degree angle.
- Two stage foam compatible pump end, interchangeable with our 4 stage pump end for increased volume.
- Engine and pump are coupled with our stainless steel quick release clamp
- Maintenance-free speed increaser
- Choice of hand carrying tube frame or a channel base frame for vehicle mount
- Hand priming pump and pressure gauge included
- Optional Remote Fuel (RFT) connection
- Our value protection model comes standard with our low pressure shut-off and RFT connection for extended run time

## WEIGHT & DIMENSIONS

Length	33.0"	84 cm
Width	18.5"	47 cm
Height	19.0"	48 cm
Weight	126 lbs	57.2 kg
Suction	2.0" NPSH	50 mm
Discharge	1.5" NPSH	38 mm

## ENGINE

Briggs and Stratton	4 stroke; 14 Hp @ 3600 RPM
Oil filter	Cartridge-type spin-on filter
Ignition	Electronic
Integral tank	1.6 Gal US                      6 liters

Specifications subject to change without notice

**FIRE PUMPS** PORTABLE  
115-160 LBS / 53-73 KG



**PORTABLE FOUR STAGE  
HIGH PRESSURE FIRE PUMP**

- Powered by an 18 HP, 4 stroke, Briggs and Stratton Vanguard "V Twin" air cooled engine with over-speed protection
- Electric start (battery optional) with manual recoil backup
- Automotive style air cleaner and external oil filter
- Four stage foam compatible pump end, interchangeable with our 4 stage fire pumps and with our F200 two stage pump end for increased volume
- Engine and pump are coupled with our stainless steel quick release clamp
- Maintenance-free speed increaser
- Choice of hand carrying tube frame or a channel base frame for vehicle mount
- Hand priming pump and pressure gauge included
- Non-return discharge valve included
- Optional integral fuel tank

**WICK XP4-18**

	Part#	Description
A	71WK4203-18BC	WICK® XP4-18 Pumper ..18 HP 4 Stroke Briggs & Stratton , 4 stage pump, Channel frame model for vehicle mount
A1	71WK4203-18BT	WICK® XP4-18 Pumper ..18 HP 4 Stroke Briggs & Stratton , 4 stage pump, Tubular frame model for easy transportation
B	71WK4203-18BCH	WICK® XP4-18 Pumper ..18 HP 4 Stroke Briggs & Stratton , 4 stage pump, Horizontal Speed increaser model with channel frame
C	71WICK4203-18BIT	WICK® XP4-18 Pumper .. 18 HP Briggs & Stratton , 4 Stage pump end, Tubular frame model for easy transportation, Integral tank



**OPTIONAL**

	Part#	Description
A	71W42-2715	Large Control Panel
B	71W42-2083	Exhaust Primer
C	70FLPFTXX	Fuel Tank .. see fuel section for complete listing
D	70FLPFL-XX	Fuel line .. see fuel section for complete listing
E	70FLPFL-ADPM	Remote fuel line Male valve fitting (Mercury)
E1	70FLPFL-ADPM-SW	Base mounted fuel line Male valve fitting (Mercury)

See website for complete listing of accessory and related products

**WEIGHT & DIMENSIONS**

Length	32.0"	81 cm
Width	19.5"	50 cm
Height	18.5"	47 cm
Weight	137 lbs	62 kg
Suction	2.0" NPSH	50 mm
Discharge	1.5" NPSH	38 mm

**ENGINE**

Briggs and Stratton	4 stroke; 18 Hp @ 3600 RPM
Oil filter	Cartridge-type spin-on filter
Ignition	Electronic

Specifications subject to change without notice

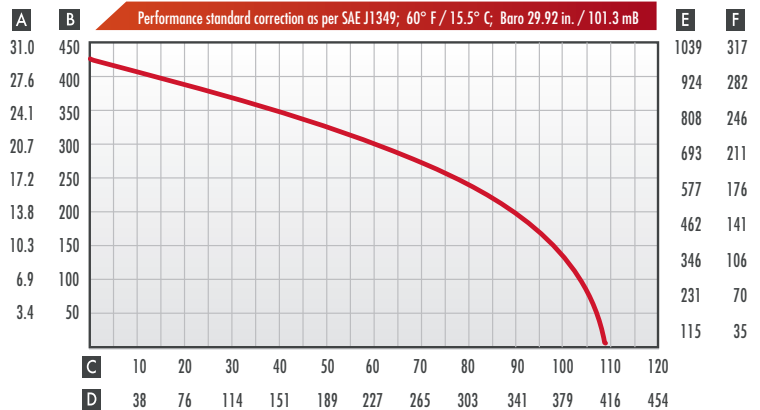

A Pressure in Bar B Pressure in PSI C Flow U.S. GPM D Flow liters / Min. E Head Press. Feet F Head Press. Meters

Wik 280 / A18A / 2H



## WICK XP2-18

	Part#	Description
A	71WICKF200-18BC	WICK® XP2-18 Pumper ..18 HP 4 Stroke Briggs & Stratton , 2 stage pump, Channel frame model for vehicle mount
A1	71WICKF200-18BT	WICK® XP2-18 Pumper ..18 HP 4 Stroke Briggs & Stratton , 2 stage pump, Tubular frame model for easy transportation
B	71WICKF200-18BCH	WICK® XP2-18 Pumper ..18 HP 4 Stroke Briggs & Stratton , 2 stage pump, Horizontal Speed increaser model with channel frame
C	71WICKF200-18BTTT	WICK® XP2-18 Pumper ..18 HP Briggs & Stratton , 2 Stage pump end, Tubular frame model for easy transportation, Integral tank

### PORTABLE TWO STAGE HIGH PRESSURE FIRE PUMP

- Powered by an 18 HP, 4 stroke, Briggs and Stratton Vanguard "V Twin" air cooled engine with over-speed protection
- Electric start (battery optional) with manual recoil backup
- Automotive style air cleaner and external oil filter
- Two stage foam compatible pump end, interchangeable with our 2 stage fire pumps and with our FSP4200 four stage pump end for increased pressure
- Engine and pump are coupled with our stainless steel quick release clamp
- Maintenance-free speed increaser
- Choice of hand carrying tube frame or a channel base frame for vehicle mount
- Hand priming pump and pressure gauge included
- Non-return discharge valve included
- Optional integral fuel tank



### OPTIONAL

	Part#	Description
A	71W42-2715	Large Control Panel
B	71W42-2083	Exhaust Primer
C	70FLPFTXX	Fuel Tank .. see fuel section for complete listing
D	70FLPFL-XX	Fuel line .. see fuel section for complete listing
E	70FLPFL-ADPM	Remote fuel line Male valve fitting (Mercury)
E1	70FLPFL-ADPM-SW	Base mounted fuel line Male valve fitting (Mercury)

See website for complete listing of accessory and related products

Performance standard correction as per SAE J1349; 60° F / 15.5° C; Baro 29.92 in. / 101.3 mB

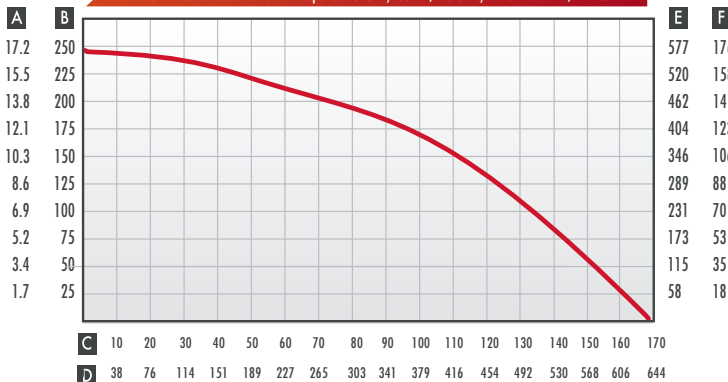

A Pressure in Bar B Pressure in PSI C Flow U.S. GPM D Flow liters / Min. E Head Press. Feet F Head Press. Meters  
W420-185 / P22A / JH

### WEIGHT & DIMENSIONS

Length	32.0"	81 cm
Width	19.5"	50 cm
Height	18.5"	47 cm
Weight	133 lbs	60 kg
Suction	2.0" NPSH	50 mm
Discharge	1.5" NPSH	38 mm

### ENGINE

Briggs and Stratton	4 stroke; 18 Hp @ 3600 RPM
Oil filter	Cartridge-type spin-on filter
Ignition	Electronic

Performance with 2.5" / 64mm foot valve and suction hose  
Specifications subject to change without notice

**FIRE PUMPS** PORTABLE  
115-160 LBS / 53-73 KG

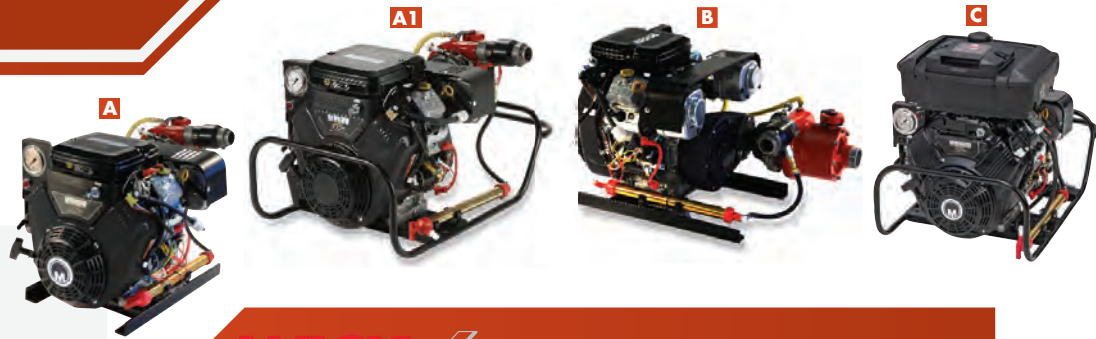

**PORTABLE FOUR STAGE  
HIGH PRESSURE FIRE PUMP**

- Powered by a 23 HP, 4 stroke, Briggs and Stratton Vanguard "V Twin" air cooled engine with over-speed protection
- Electric start (battery optional) with manual recoil backup
- Automotive style air cleaner and external oil filter
- Four stage foam compatible pump end, interchangeable with our 4 stage fire pumps and with our F200 two stage pump end for increased volume
- Engine and pump are coupled with our stainless steel quick release clamp
- Maintenance-free speed increaser
- Choice of hand carrying tube frame or channel base frame for vehicle mount
- Hand priming pump and pressure gauge included
- Non-return discharge valve included
- Optional integral fuel tank

**WICK XP4-23**

	Part#	Description
A	71WK4203-23BC	WICK® XP4-23 Pumper ..23 HP 4 Stroke Briggs & Stratton , 4 stage pump, Channel frame model for vehicle mount
A1	71WK4203-23BT	WICK® XP4-23 Pumper ..23 HP 4 Stroke Briggs & Stratton , 4 stage pump, Tubular frame model for easy transportation
B	71WK4203-23BCH	WICK® XP4-23 Pumper ..23 HP 4 Stroke Briggs & Stratton , 4 stage pump, Horizontal Speed increaser model with channel frame
C	71WICK4203-23BIT	WICK® XP4-23 Pumper .. 23 HP Briggs & Stratton , 4 Stage pump end, Tubular frame model for easy transportation, Integral tank



**OPTIONAL**

	Part#	Description
A	71W42-2715	Large Control Panel
B	71W42-2083	Exhaust Primer
C	70FLPFTXX	Fuel Tank .. see fuel section for complete listing
D	70FLPFL-XX	Fuel line .. see fuel section for complete listing
E	70FLPFL-ADPM	Remote fuel line Male valve fitting (Mercury)
E1	70FLPFL-ADPM-SW	Base mounted fuel line Male valve fitting (Mercury)

See website for complete listing of accessory and related products

**WEIGHT & DIMENSIONS**

Length	32.0"	81 cm
Width	19.5"	50 cm
Height	18.5"	47 cm
Weight	137 lbs	62 kg
Suction	2.0" NPSH	50 mm
Discharge	1.5" NPSH	38 mm

**ENGINE**

Briggs and Stratton	4 stroke; 23 Hp @ 3600 RPM
Oil filter	Cartridge-type spin-on filter
Ignition	Electronic

Specifications subject to change without notice

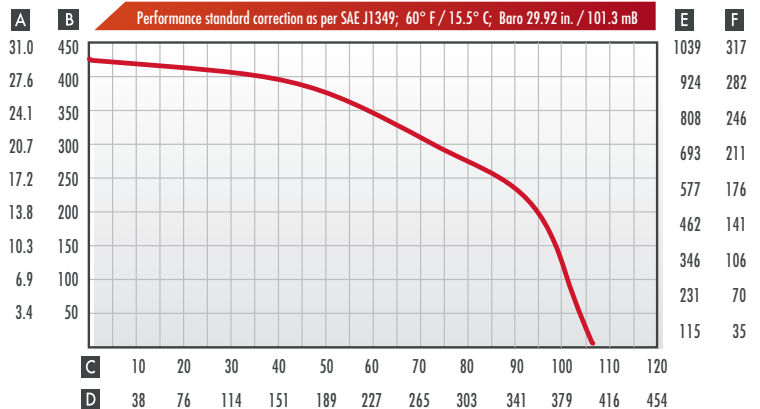

A Pressure in Bar B Pressure in PSI C Flow U.S. GPM D Flow liters / Min. E Head Press. Feet F Head Press. Meters  
W4200 23BS / 10291 / 01



## WICK XP2-23

	Part#	Description
A	71WICKF200-23BC	WICK® XP2-23 Pumper ..23 HP 4 Stroke Briggs & Stratton , 2 stage pump, Channel frame model for vehicle mount
A1	71WICKF200-23BT	WICK® XP2-23 Pumper ..23 HP 4 Stroke Briggs & Stratton , 2 stage pump, Tubular frame model for easy transportation
B	71WICKF200-23BCH	WICK® XP2-23 Pumper ..23 HP 4 Stroke Briggs & Stratton , 2 stage pump, Horizontal Speed increaser model with channel frame
C	71WICKF200-23BIT	WICK® XP2-23 Pumper .. 23 HP Briggs & Stratton , 2 Stage pump end, Tubular frame model for easy transportation, Integral tank

### PORTABLE TWO STAGE HIGH PRESSURE FIRE PUMP

- Powered by a 23 HP, 4 stroke, Briggs and Stratton Vanguard "V Twin" air cooled engine with over-speed protection
- Electric start (battery optional) with manual recoil backup
- Automotive style air cleaner and external oil filter
- Two stage foam compatible pump end, interchangeable with our 2 stage fire pumps and with our FSP4200 four stage pump end for increased pressure
- Engine and pump are coupled with our stainless steel quick release clamp
- Maintenance-free speed increaser
- Choice of hand carrying tube frame or a channel base frame for vehicle mount
- Hand priming pump and pressure gauge included
- Non-return discharge valve included
- Optional integral fuel tank



### OPTIONAL

	Part#	Description
A	71W42-2715	Large Control Panel
B	71W42-2083	Exhaust Primer
C	70FLPFTXX	Fuel Tank .. see fuel section for complete listing
D	70FLPFL-XX	Fuel line .. see fuel section for complete listing
E	70FLPFL-ADPM	Remote fuel line Male valve fitting (Mercury)
E1	70FLPFL-ADPM-SW	Base mounted fuel line Male valve fitting (Mercury)

See website for complete listing of accessory and related products

Performance standard correction as per SAE J1349; 60° F / 15.5° C; Baro 29.92 in. / 101.3 mB

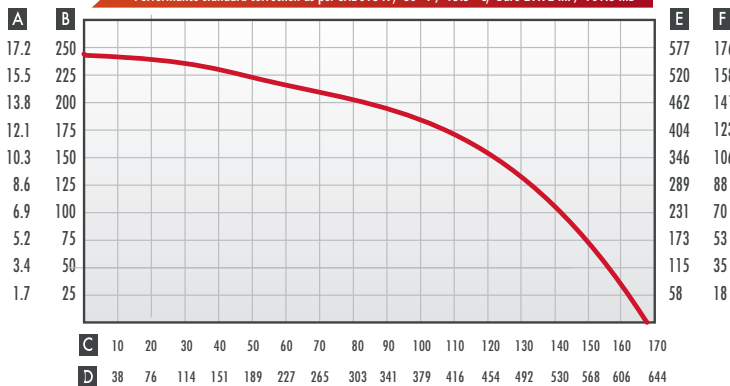

A Pressure in Bar B Pressure in PSI C Flow U.S. GPM D Flow liters / Min. E Head Press. Feet F Metric Head Press.  
181P Uhefu / 12M / 78

### WEIGHT & DIMENSIONS

Length	32.0"	81 cm
Width	19.5"	50 cm
Height	18.5"	47 cm
Weight	133 lbs	60 kg
Suction	2.0" NPSH	50 mm
Discharge	1.5" NPSH	38 mm

### ENGINE

Briggs and Stratton	4 stroke; 23 Hp @ 3600 RPM
Oil filter	Cartridge-type spin-on filter
Ignition	Electronic

Performance shown using 2 1/2" / 64mm suction hose and foot valve  
Specifications subject to change without notice

# FIRE PUMPS PORTABLE

115-160 LBS / 53-73 KG



## WICK ULTRAFLO™

20 HP HONDA

### PORTABLE TWO STAGE HIGH FLOW; HIGH PRESSURE FIRE PUMP

- Powered by a 20 HP, 4 stroke, Honda air cooled engine with over-speed protection
- Electric start (battery optional)
- Automotive style air cleaner and external oil filter
- Foam compatible pump end, interchangeable with our other 2, 3 and 4 stage pump ends
- The pump end comes standard with two drain valves
- Engine and pump are coupled with our stainless steel quick release clamp
- Maintenance-free speed increaser
- Choice of hand carrying tube frame or a channel base frame for vehicle mount
- Hand priming pump and pressure gauge included
- Standard 3" / 76mm NPSH to NH adaptor on intake
- Available discharge Shut-off valve 2 1/2" NH Male x 2 1/2" NH Female

Part#	Description
71WKF8225-20HCH	WICK ULTRAFLO Pumper ..20 HP Honda, 4 stroke, Electric start, 2 stage pump, Horizontal SI, Channel frame model for vehicle mount



### OPTIONAL

	Part#	Description
A	71W42-2715	Large Control Panel
B	70FLPFTXX	Fuel Tank .. see website for complete listing
C	70FLPFL-XX	Fuel line .. see website for complete listing
D1	6140NF40NM	Thread protector 2 1/2" / 64mm
D2	6148NM48PF	Adaptor .. 3" / 72mm NH Male x 3" / 76mm NPSH Female
D3	70FLFV-4450	Adaptor .. 4" / 102mm NH Male x 3" / 76mm NH Female
E	70FL30SHNH10-R	Ultraflo suction hose .. 3"/76mm x 10'/3M c/w NH
F	70FLFV64NF	Foot Valve / Strainer 4.0"/102mm
G	70FLPFL-ADPM*	Remote fuel line Male valve fitting (Mercury) * Other fuel fittings available, please specify
H	70FL25S025NFM	Shut-off valve 2 1/2" NH Male x 2 1/2" NH Female

See website for complete listing of accessory and related products

### WEIGHT & DIMENSIONS

Length	28.0"	71.1 cm
Width	21.0"	53.3 cm
Height	19.5"	49.5 cm
Weight	170.3 lbs	77.3 kg
Suction	3.0" NH	76 mm
Discharge	2.5" NH	64 mm

### ENGINE

Honda	4 stroke; 20 Hp @ 3600 RPM
Oil filter	Cartridge-type spin-on filter
Ignition	Electronic

Performance shown using 3.0" / 76mm suction hose  
Specifications subject to change without notice

Performance standard correction as per SAE J1349; 60° F / 15.5° C; Baro 29.92 in. / 101.3 mB



C 20 40 60 80 100 120 140 160 180 200 220 240 260 280 300 320

D 80 160 240 320 400 480 560 640 720 800 880 960 1040 1120

A Pressure in Bar B Pressure in PSI C Flow U.S. GPM D Flow liters / Min. E Head Press. Feet F Metric Head Press.



CONTINUED NEXT PAGE ..

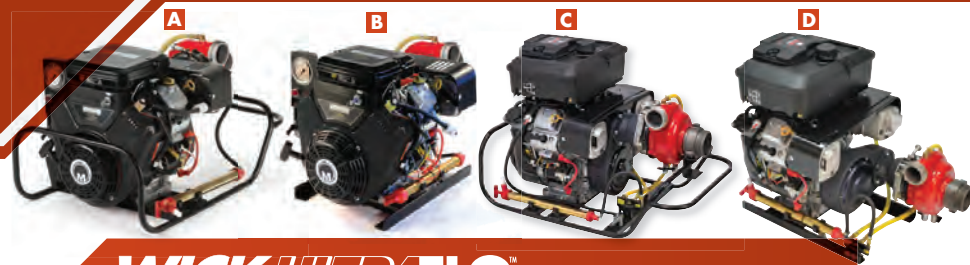

**WICK ULTRAFLO™**  
18-HP

PORTABLE TWO STAGE  
HIGH FLOW; HIGH PRESSURE  
FIRE PUMP

- Powered by an 18 HP, 4 stroke, Briggs and Stratton Vanguard "V Twin" air cooled engine with over-speed protection
- Available 23HP
- Electric start (battery optional) with manual recoil backup
- Automotive style air cleaner and external oil filter
- Foam compatible pump end, interchangeable with our other 2, 3 and 4 stage pump ends
- The pump end comes standard with two drain valves
- Engine and pump are coupled with our stainless steel quick release clamp
- Maintenance-free speed increaser
- Choice of hand carrying tube frame or channel base frame for vehicle mount
- Hand priming pump and pressure gauge included
- Standard 3" / 76mm NPSH to NH adaptor on intake
- Available with optional integral fuel tank (6.95 Qt / 6.6 L) and remote fuel connection
- Available with "Low pressure shut-off" to protect the pump on loss of prime

	Part#	Description
A	71WKFB225-18BT	WICK ULTRAFLO Pumper ..18 HP 4 Stroke Briggs & Stratton , Electric start, 2 stage pump, No Intergral tank Vertical SI, Tubular frame for easy transportation
B	71WKFB225-18BC	WICK ULTRAFLO Pumper ..18 HP 4 Stroke Briggs & Stratton , Electric start, 2 stage pump, No Intergral tank, Vertical SI, Channel frame model for vehicle mount
C	71WKFB225-18BTT	WICK ULTRAFLO Pumper ..18 HP 4 Stroke Briggs & Stratton , Electric start, 2 stage pump, Intergral tank, Vertical SI, Tubular frame for easy transportation
D	71WKFB225-18BCTH	WICK ULTRAFLO Pumper ..18 HP 4 Stroke Briggs & Stratton , Electric start, 2 stage pump, Intergral tank, Horizontal SI, Channel frame model for vehicle mount



OPTIONAL

	Part#	Description
A	71W42-2715	Large Control Panel
B	70FLPFTXX	Fuel Tank .. see website for complete listing
C	70FLPFL-XX	Fuel line .. see website for complete listing
D1	6140NF40NM	Thread protector 2 1/2" / 64mm
D2	6148NM48PF	Adaptor .. 3" / 72mm NH Male x 3" / 76mm NPSH Female
D3	70FLV-4450	Adaptor .. 4" / 102mm NH Male x 3" / 76mm NH Female
E	70FL30SHNH10-R	Ultraflo suction hose .. 3"/76mm x 10'/3M c/w NH
F	70FLV64NF	Foot Valve / Strainer 4.0"/102mm
G	70FLPFL-ADPM*	Remote fuel line Male valve fitting (Mercury) * Other fuel fittings available, please specify
H	70FL25S025NFNM	Shut-off valve 2 1/2" NH Male x 2 1/2 NH Female

See website for complete listing of accessory and related products

WEIGHT & DIMENSIONS

Length	32.5"	82.5 cm
Width	19.5"	50 cm
Height *	24.0"	61 cm
Weight *	160 lbs	72.6 kg
Suction	3.0" NH	76 mm
Discharge	2.5" NH	64 mm

ENGINE

Briggs & Stratton Vanguard	4 stroke; 18 Hp
@ 3600 RPM	
Oil filter	Cartridge-type spin-on filter
Ignition	Electronic

\* Weight and Height with integral fuel tank  
Performance shown using 3.0" / 76mm suction hose  
Specifications subject to change without notice

Performance standard correction as per SAE J1349; 60° F / 15.5° C; Baro 29.92 in. / 101.3 mB

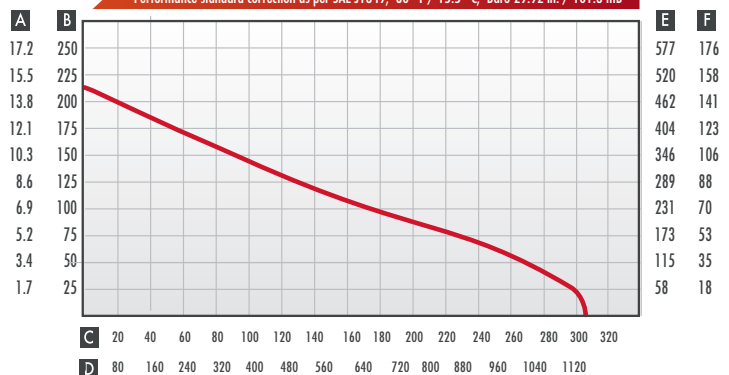

A Pressure in Bar B Pressure in PSI C Flow U.S. GPM D Flow liters / Min. E Head Press. Feet F Metric Head Press.

18HP Ultraflo / 220 / 20



**WICK ULTRAFLO™**  
23<sub>HP</sub>

	Part#	Description
A	71WKFB225-23BT	WICK ULTRAFLO Pumper ..23 HP 4 Stroke Briggs & Stratton , Electric start, 2 stage pump, No Intergral tank Vertical SI, Tubular frame for easy transportation
B	71WKFB225-23BC	WICK ULTRAFLO Pumper ..23 HP 4 Stroke Briggs & Stratton , Electric start, 2 stage pump, No Intergral tank, Vertical SI, Channel frame model for vehicle mount
C	71WKFB225-23BTTT	WICK ULTRAFLO Pumper ..23 HP 4 Stroke Briggs & Stratton , Electric start, 2 stage pump, Intergral tank, Vertical SI, Tubular frame for easy transportation
D	71WKFB225-23BCITH	WICK ULTRAFLO Pumper ..23 HP 4 Stroke Briggs & Stratton , Electric start, 2 stage pump, Intergral tank, Horizontal SI, Channel frame model for vehicle mount



**OPTIONAL**

	Part#	Description
A	71W42-2715	Large Control Panel
B	70FLPFTXX	Fuel Tank .. see website for complete listing
C	70FLPFL-XX	Fuel line .. see website for complete listing
D1	6140NF40NM	Thread protector 2 1/2" / 64mm
D2	6148NM48PF	Adaptor .. 3" / 72mm NH Male x 3" / 76mm NPSH Female
D3	70FLFV-4450	Adaptor .. 4" / 102mm NH Male x 3" / 76mm NH Female
E	70FL30SHNH10-R	Ultraflo suction hose .. 3"/76mm x 10'/3M c/w NH
F	70FLFV64NF	Foot Valve / Strainer 4.0"/102mm
G	70FLPFL-ADPM*	Remote fuel line Male valve fitting (Mercury) * Other fuel fittings available, please specify
H	70FL25SO25NFM	Shut-off valve 2 1/2" NH Male x 2 1/2" NH Female

See website for complete listing of accessory and related products

Performance standard correction as per SAE J1349; 60° F / 15.5° C; Baro 29.92 in. / 101.3 mB

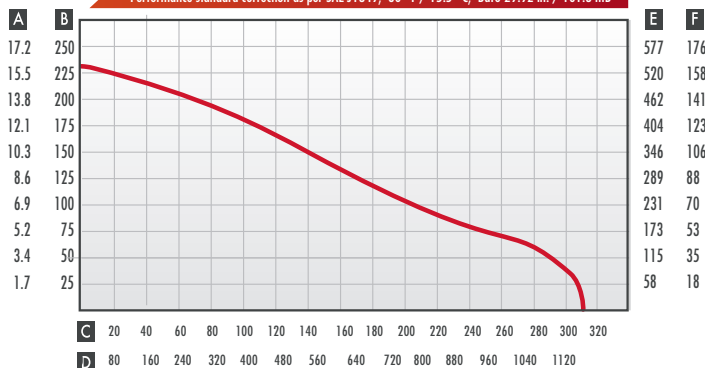

A Pressure in Bar B Pressure in PSI C Flow U.S. GPM D Flow liters / Min. E Head Press. Feet F Metric Head Press.

**PORTABLE TWO STAGE  
HIGH FLOW; HIGH PRESSURE  
FIRE PUMP**

- Powered by an 23 HP, 4 stroke, Briggs and Stratton Vanguard "V Twin" air cooled engine with over-speed protection
- Available 18HP
- Electric start (battery optional) with manual recoil backup
- Automotive style air cleaner and external oil filter
- Low oil indicator light
- Foam compatible pump end, interchangeable with our other 2, 3 and 4 stage pump ends
- The pump end comes standard with two drain valves
- Engine and pump are coupled with our stainless steel quick release clamp
- Maintenance-free speed increaser
- Choice of hand carrying tube frame or a channel base frame for vehicle mount
- Hand priming pump and pressure gauge included
- Standard 3" / 76mm NPSH to NH adaptor on intake
- Available with optional integral fuel tank (6.95 Qt / 6.6 L) and remote fuel connection
- Available with "Low pressure shut-off" to protect the pump on loss of prime

**WEIGHT & DIMENSIONS**

Length	32.5"	82.5 cm
Width	19.5"	50 cm
Height *	24.0"	61 cm
Weight *	163 lbs	74 kg
Suction	3.0" NH	76 mm
Discharge	2.5" NH	64 mm

**ENGINE**

Briggs & Stratton Vanguard	4 stroke; 23 Hp @ 3600 RPM
Oil filter	Cartridge-type spin-on filter
Ignition	Electronic

\* Weight and Height with integral fuel tank  
Performance shown using 3.0"/76mm suction hose  
Specifications subject to change without notice



**PORTABLE FLOATING  
HIGH PRESSURE FIRE PUMP**

- The floating fire pump meets the rugged demands of forestry services and also used for marine service, dewatering, pool maintenance, environmental clean-up and irrigation.
- Unique hard anodized aluminum impeller and housing
- Unique electronic overspeed protection
- Pump end is designed for easy field maintenance
- Unique fuel lever gauge
- Face-type mechanical seal is standard. No adjustment required
- Built-in intake screen
- Water-resistant air cleaner and muffler
- 8 horsepower, 8.20 cu. in. (134cc) displacement, air-cooled
- Recoil hand starter
- Carburetor with integral fuel pump
- Solid-state ignition
- Electronic over-speed protection cut-out switch
- Nikasil plated cylinder bore
- Ball bearing-supported crankshaft
- Roller bearing-equipped connecting rod
- Uses unleaded gasoline and oil mixed
- Automatic float controlled throttle

**WICK® FT200**

Part#	Description
71WICKFT-200	WICK FT-200 High pressure floating pump

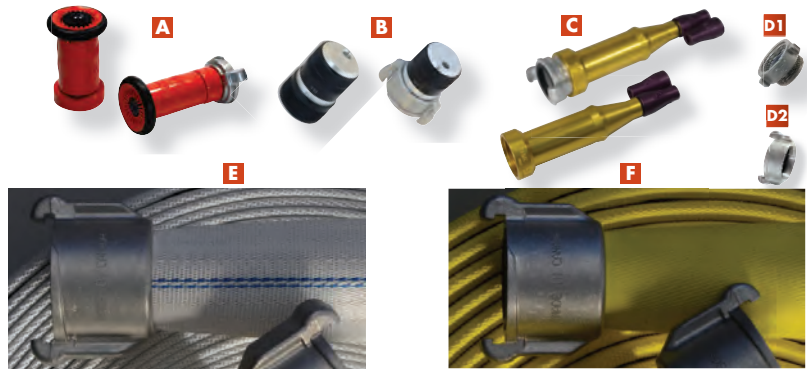

**OPTIONAL**

	Part#	Description
A	70FL15ZFGXX	Nozzle .. Fog / Straight Stream 1 1/2" / 38mm .. see nozzle section
B	70FL15ZMONXX	Nozzle .. Multi-Orifice - 1 1/2" / 38mm .. see nozzle section
C	70FL15ZBEBXX	Nozzle .. Barrel / Straight Stream 1 1/2" / 38mm Alum. .. see nozzle section
D1	70FL15TPPS	Thread protector 1 1/2" / 38mm
D2	6324PF24QCA	Forged Adaptor 1 1/2" / 38mm NPSH Female x 1 1/2" / 38mm Quick Connect
E	FIREBREAK II®	See hose section
F	FIREBOSS®	See hose section

**WEIGHT & DIMENSIONS**

LENGTH	29.5"	74.9 CM
WIDTH	20.0"	50.8 CM
HEIGHT	16.5"	41.9 CM
WEIGHT (DRY)	43 LBS	19.5 KG

DISCHARGE 1 1/2" 38 mm NPSH\*  
\*Standard NPSH threads, other discharge threads available

**ENGINE**

HYDROWICK	2 STROKE	
POWER	8 HP	
CYLINDER	NIKASIL	
IGNITION	ELECTRONIC	
FUEL TANK	5 QUART	4.7 LITER

Specifications subject to change without notice

Performance standard correction as per SAE J1349; 60° F / 15.5° C; Baro 29.92 in. / 101.3 mB

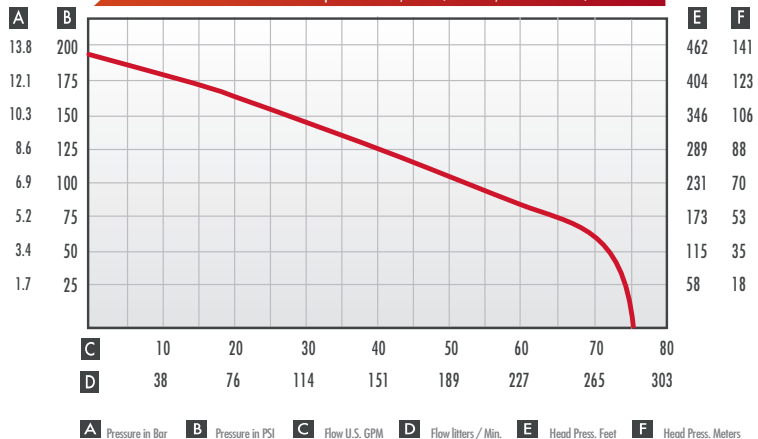



**WICK® FT200-4B**

	Part#	Description
A	71WICKFT-200-4BX	WICK® FT-200-4B Fire Pump with standard 9.5 liter tank
B	71WICKFT-200-4B	WICK® FT-200-4B Fire Pump with optional 4.7 liter tank (not avail in US)

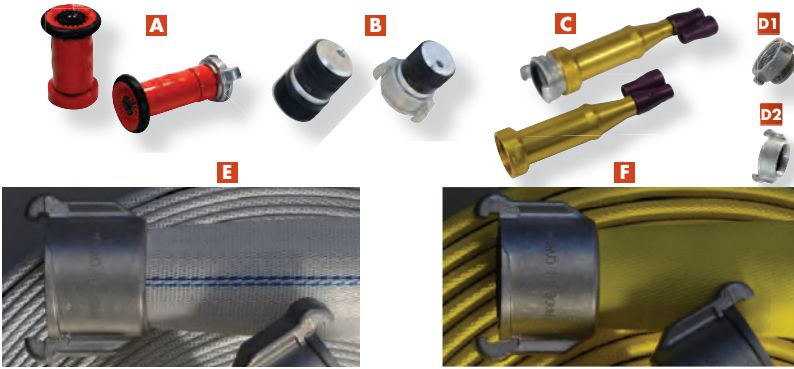

**OPTIONAL**

	Part#	Description
A	70FL15ZFGXX	Nozzle .. Fog / Straight Stream 1 1/2" / 38mm .. see nozzle section
B	70FL15ZMONXX	Nozzle .. Multi-Orifice - 1 1/2" / 38mm .. see nozzle section
C	70FL15ZBEBXX	Nozzle .. Barrel / Straight Stream 1 1/2" / 38mm Alum. .. see nozzle section
D1	70FL15TPPS	Thread protector 1 1/2" / 38mm
D2	6324PF24QCA	Forged Adaptor 1 1/2" / 38mm NPSH Female x 1 1/2" / 38mm Quick Connect
E	FIREBREAK II®	See hose section
F	FIREBOSS®	See hose section

Performance standard correction as per SAE J1349; 60° F / 15.5° C; Baro 29.92 in. / 101.3 mB

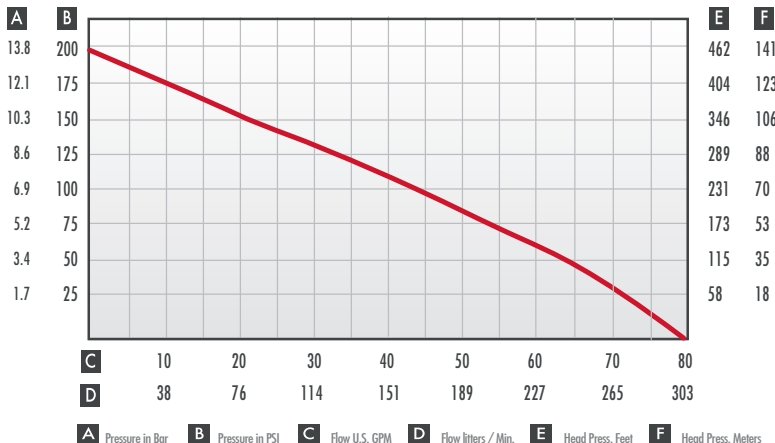

**PORTABLE FLOATING  
HIGH PRESSURE FIRE PUMP**

- Floating fire pumps can be deployed rapidly without the need for suction hose or foot valves. They are also practical for shallow water applications
- This rugged Fire pump meets the Fire Fighting demands of municipal and forestry services. Other applications include dewatering, marine, environmental clean-up, irrigation, power washing and many more
- Powered by a reliable, high performance Briggs and Stratton EPA approved 4-Stroke air-cooled engine with low fuel consumption and an acoustically-engineered muffler for quiet operation. Also equipped with a recoil hand starter and Over-speed protection
- Featuring "ReadyStart"® starting system and Automatic Choke for super easy starting
- The only high pressure 4 Stroke floating pump on the market with nearly 3 times the pressure of other 4 stroke floating pumps and at less than 2/3 the weight!
- This pump is designed with ease of maintenance in mind with a Built-in easily removable intake screen
- Hard Anodized Aluminum casing and Impeller for added corrosion resistance
- Face-type spring-loaded mechanical seal is standard. No adjustment required
- Stainless steel pump shaft and hardware for added corrosion resistance
- The float has 'Molded' carrying handles front, rear and on the sides for easy transport
- 9.5 liter tank 4 1/2 hour run time .. standard model Optional 4.7 liter tank (not available in US)

**WEIGHT & DIMENSIONS**

LENGTH	38.75"	98.4 cm
WIDTH	25.0"	63.5 cm
HEIGHT	23"	58.4 cm
WEIGHT (DRY)	74 Lbs	33.6 Kg
DISCHARGE	1 1/2"	38 mm NPSH

Standard NPSH threads, other discharge threads available

**ENGINE**

BRIGGS AND STRATTON	PROFESSIONAL SERIES** 4 STROKE
DISPLACEMENT	223 cc
OIL CAPACITY	18 oz. / 0.54 L
FUEL TANK	2.50 US Gal. / 9.46 L
FUEL TANK (OPTIONAL)	1.25 US Gal. / 4.73 L

\* ReadyStart® is a trade mark of Briggs & Stratton

\*\* This "Professional" series engine has a 60% longer life than the "E" series engine

Specifications subject to change without notice

**ATV SLIP-ON UNIT COMPLETE WITH HIGH PRESSURE FIRE PUMP**

- 65 US Gallon (246 liters) NFPA compliant Baffled Tank
- WICK® 100-4H high pressure fire pump
- Pressure gauge
- Safety Bypass bleed line with Rapid Pump powered tank refill option
- The unit is designed so that the pump can be easily and quickly disconnected. Two thumb screws hold the pump in place should the portable pump be needed elsewhere
- Overboard connection for connecting the suction hose for use with an external water source
- Inlet available to connect an external water source for refilling the tank
- 1 ½" (38mm) discharge with shut-off valve, plus an auxiliary 1 ½" (38mm) connection with cap. Available with various threads or forged QC connections

**OPTIONAL:**

- Stainless steel Hannay reel mounted on the tank. Includes 100' (30.5 M) section of ¾" (19 mm) Boostlite® reel hose, plus valve for emergency shutoff
- Poppet check valve and hand primer for rapid priming
- Discharge hose (sections of 1 ½" (38 mm) x 75' (23 M) Fireboss® fire hose)
- Various discharge threads .. NH; NPSH; BSP; QC
- Choice of nozzle
- Jack Stack (NH & NPSH)
- Suction Hose
- Foot Valve



**COMPLETE UNIT WEIGHT & DIMENSIONS**

Length (Depth)	36.0"	91 cm
Width	47.0"	119 cm
Height	36.0"	91 cm
Weight tank only (Dry)	135 lbs	61 Kg
Weight complete unit (Dry)	250 lbs	113 Kg
Weight complete unit with full tank of water	790 lbs	358 Kg

Specifications subject to change without notice

**WICK®** ATV SLIP-ON

Part#	Description
74SL065W104	ATV Slip-on unit complete with 65 US gal/246L tank, Wick 100-4H high pressure fire pump, choice of discharge threads (NH; NPSH; BSP; QC)

**WICK® 100-4H PERFORMANCE**

Performance standard correction as per SAE J1349; 60° F / 15.5° C; Baro 29.92 in. / 101.3 mB

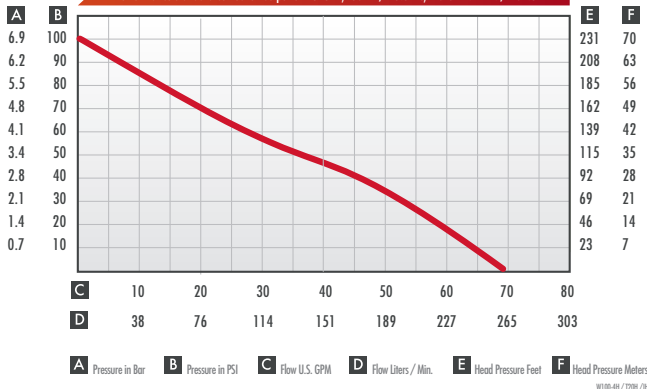

# WICK® P/U TRUCK SLIP-ON



## P/U TRUCK SLIP-ON UNIT COMPLETE WITH HIGH PRESSURE FIRE PUMP

- 125 US Gallon (473 liters) NFPA compliant Baffled Tank
- WICK® SI 250 or WICK® SI 300 mounted on the tank
- Safety Bypass bleed line with Rapid Pump powered tank refill option
- Adjustable relief valve with 4' (1.2 M) of 3/4" (19 mm) bleeder line
- Storage hose trays front and back of the baffled tank for attack hose and suction hose storage
- OPTIONAL :
  - Hannay electric reel (aluminum base and stainless steel drum) mounted on the tank with control switch and feeder line. Also includes :
    - - 100 feet (30.5 M) section of 3/4" (19mm) Boostlite® reel hose
    - - 1.0" (25 mm) Fog/straight stream nozzle
    - - Valve for emergency shutoff
  - Five sections of Drafilite® Suction Hose to fit in the back storage tray
    - - Four sections of 2.0" (51mm) x 4' (1.22M)
    - - One section of 2.0" (51mm) x 3.5' (1.07M) with 2" (51mm) foot valve
  - Delivery hose to fit in the front storage tray which includes :
    - - Two sections of 1 1/2" (38 mm) x 75' (23 M) Fireboss® fire hose
    - - Available with Aluminum threaded or Forged QC couplings
    - - Multi-orifice nozzle connected to the above Fireboss® fire hose
  - Spare Aluminum Barrel Nozzle with threaded or QC connection
  - Hose wrenches
  - Battery Box with battery, mounted on the tank
  - Jack stack
  - Drip Torch
  - Rigid back tank with hand pump sprayer

## WICK® P/U TRUCK SLIP-ON

Part#	Description
74SL125WSI3	Pick-up Slip-on unit complete with 125 US gal/473L tank, Wick SI 300 high pressure fire pump, choice of discharge threads (NH, NPSH; BSP; QC)
74SL125WSI2	Pick-up Slip-on unit complete with 125 US gal/473L tank, Wick SI 250 high pressure fire pump, choice of discharge threads (NH; NPSH; BSP; QC)

### COMPLETE UNIT WEIGHT & DIMENSIONS\*

Length (Depth)*	54.5"	138 cm
Width	48"	122 cm
Height	41"	90 cm
Weight .. with WICK SI 250 (dry)**	525 lbs	239 Kg
Weight .. with WICK SI 300 (dry)**	550 lbs	250 Kg

### TANK ONLY

Length (Depth)	37.5"	83 cm
Width	47.0"	103 cm
Height	20.5"	45 cm

\* Length (Depth) including front and rear hose trays

\*\* Weight includes complete unit with all optional components

Specifications subject to change without notice

### WICK® SI250 PERFORMANCE

Performance standard correction as per SAE J1349; 60° F / 15.5° C; Baro 29.92 in. / 101.3 mB



### WICK® SI300 PERFORMANCE

Performance standard correction as per SAE J1349; 60° F / 15.5° C; Baro 29.92 in. / 101.3 mB

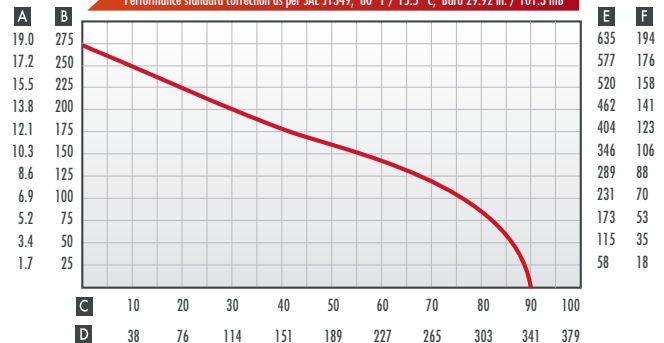



- Four stage foam compatible pump. Applications for this pump are in the field where high pressure and long hose lays are required. Attachment to engine is via a quick-connect pump mounting clamp (see part 79W212)
- 2"/50mm NPSH Suction, 1 1/2"/38mm NPSH Discharge

## W4 4-STAGE



Bottom Drain

### WICK® W4 FOUR STAGE PUMP END

Part#	Description
79W1216S	WICK W4 .. 4 Stage Pump end complete .. sealed bearing
79W1216S-D	WICK W4 .. 4 Stage Pump end complete .. sealed bearing (with bottom drain)

- Three stage foam compatible pump. Applications for this pump are in the field where medium type pressures and high volumes are required.
- 2"/50mm NPSH Suction, 1 1/2"/38mm NPSH Discharge

## W3 3-STAGE



Bottom Drain

### WICK® W3 THREE STAGE PUMP END

Part#	Description
71FSP3200	WICK W3 .. 3 Stage Pump End Complete .. sealed bearing
71FSP3200-D	WICK W3 .. 3 Stage Pump End Complete with bottom drain .. sealed bearing

- Two stage foam compatible pump. Applications for this pump are in the field where medium type pressures and high volumes are required.
- 2"/50mm NPSH Suction, 1 1/2"/38mm NPSH Discharge

## W2 2-STAGE



Bottom Drain

### WICK® W2 TWO STAGE PUMP END

Part#	Description
71F201 S	WICK W2 .. 2 Stage Pump end complete .. sealed bearing
71F201 S-D	WICK W2 .. 2 Stage Pump end complete .. sealed bearing (with bottom drain)

- Made of stainless steel for extended life and utilized for mounting 2 and 4 stage pump ends to our WICK® pump engines, without the need for tools.



### PUMP MOUNTING CLAMP

Part#	Description
79W212	Pump Mounting Clamp

- This compact, sturdy grease gun is made of metal and measures 8" (20.5 cm) for easy storage. Designed to be used on the FSP 4200™ and the F200™ pump ends



### PUSH TYPE GREASE GUN

Part#	Description
78T-B1933	Grease Gun - Push Type



**LARGE CONTROL PANEL FOR OUR BRIGGS & STRATTON PUMPS**

Part#	Description
71W42-2715	Large Control Panel for Briggs & Stratton Engine Pumps (totally enclosed deck mount)

- Anodized Panel with a quick connect wiring harness to engine, 0 to 600psi (0 to 41 Bar) liquid filled gauge, hour meter, volt meter, panel light, auto reset automotive style circuit breakers, low water pressure cut-out switch, protection bypass button for starting, low oil Pressure warning light, vernier throttle control, and choke control



**EXHAUST PRIMER FOR OUR BRIGGS & STRATTON PUMPS**

Part#	Description
71W42-2083	Exhaust Primer for Briggs & Stratton Engine Pumps 18HP engine
71W42-2083-23	Exhaust Primer for Briggs & Stratton Engine Pumps 23HP engine

- This optional feature uses the engine exhaust to perform the essential task of priming the pump. Specify hand or exhaust priming when ordering



**BACK BOARDS WITH CARRYING STRAPS**

	Part#	Description
A	71W25-HPACK	Back Board with Carrying straps (for use with WICK 80, WICK 100M, and WICK 250 fire pumps)
B	71W25-HPACKPD	Back Board with Padded Carrying straps (for use with the WICK 80, WICK 100M, and WICK 250 fire pumps)
C	71W37-HPACK	Back Board with padded carrying straps (for use with the WICK 375 and WICK 200 fire pumps)
D	71W104-HPACK	Back Board with padded carrying straps for WICK 100-4H

- Back boards and carrying straps for various portable pumps.



**OPTIONAL**

	Part#	Description
A	70FLBTR5-STRAP	Non-padded straps (Price each)
B	70FLBTR5-STRAPC	Padded straps (Price each)



# FIRE PUMP ACCESSORIES

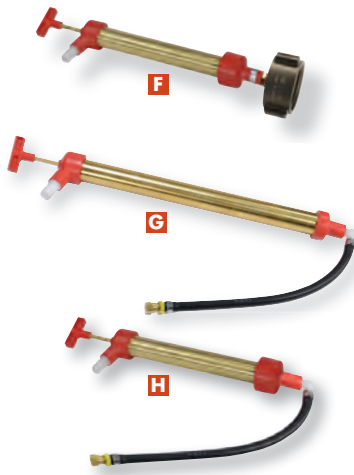

- Versatile hand primers are a quick and easy way to prime fire pumps

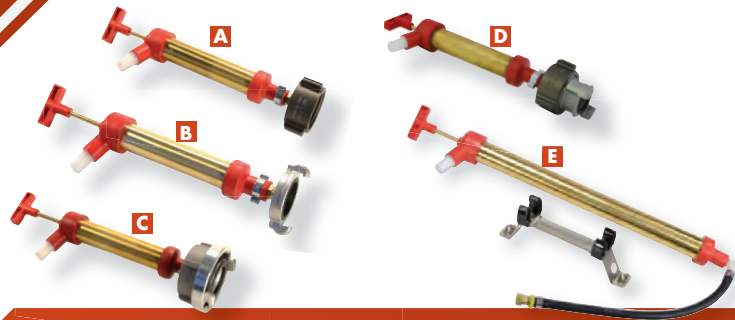

## HYDRO-WICK® HAND PRIMERS

	Part#	Description
A	70FLHPPBS	Hand Primer - 1 1/2"/38mm BSP Female .. 5"/12.5cm stroke
A	70FLHPPNH	Hand Primer - 1 1/2"/38mm NH (NST) Female .. 5"/12.5cm stroke
A	70FLHPPPS	Hand Primer - 1 1/2"/38mm NPSH Female .. 5"/12.5cm stroke
B	70FLHPPQC	Hand Primer - 1 1/2"/38mm Quick Connect .. 5"/12.5cm stroke
C	70FLHPPRZ	Hand Primer - 2"/51mm Storz .. 5"/12.5cm stroke
C	70FLHPPRZ15	Hand Primer - 1 1/2"/38mm Storz .. 5"/12.5cm stroke
C	70FLHPPRZ17	Hand Primer - 1 3/4"/44mm Storz .. 5"/12.5cm stroke
D	70FLHPPSW15	Hand Primer - 1 1/2"/38mm Sweden .. 5"/12.5cm stroke
E	71W42-PRIMERC	Hand Primer for tube frame Pump c/w Hose, SAE connection plus mounting clip
F	70FLHPP07NH	Hand Primer - 1 1/2"/38mm NH (NST) Female 7.5"/19cm stroke
G	71W42-PRIMER	Hand Primer for tube frame Pump c/w 12"/30.5cm Hose and SAE connection
H	71W42-PRIMERTC	Hand Primer - c/w 12"/30.5cm Hose and SAE connection .. 7.5"/19cm stroke
N/I	70FLHPP-RHD	Replacement handle for hand primer pump



- 90 degree NPSH elbow is made of aluminum and designed to facilitate connections with slip on units

## 90 DEGREE ELBOW

Part#	Description
6216PM24PFELB	ELBOW 90 DEG. 1"NPSH Male x 1 1/2" NPSH Swivel Female
6224PM24PFELB	ELBOW 90 DEG. 1 1/2"NPSH Male x 1 1/2" NPSH Swivel Female



## MANIFOLD

- Manifold designed to split pump discharge into multiple discharge outlets. Two models to facilitate desired pump end rotation and configuration. Multiple thread options available with the use of adaptors.

	Part#	Description
A	70FLM15PF2NM10PM-A	Manifold 1 1/2" NH Male x 1 1/2" NPSH Swivel Female x 1 1/2" NH Male with 1" NPSH side port .. c/w caps
B	70FLM15PF2NM10PM-B	Manifold 1 1/2" NH Male x 1 1/2" NH Male x 1 1/2" NPSH Swivel Female with 1" NPSH side port .. c/w caps
C	70FL15PF3NM-C	Manifold .. 1 1/2" NH Female in by 3 x 1 1/2" NH male out c/w caps
C	70FL15PF3PM-C	Manifold .. 1 1/2" NPSH Female in by 3 x 1 1/2" NH male out c/w caps



**CHECK VALVE**

	Part#	Description
A	70FL15CVBSP	Check Valve - 1 1/2"/38mm BSP
A	70FL15CVNH	Check Valve - 1 1/2"/38mm NH (NST)
A	70FL15CVPS	Check Valve - 1 1/2"/38mm NPSH
B	70FL15CVQC	Check Valve - 1 1/2"/38mm Forged QC
C	70FL25CVQCQC	Check Valve, 2 1/2"/64mm QC, Swivel QC
D	70FL25CVBA	Check Valve, 2 1/2"/64mm BAT, Swivel BAT Female
D	70FL25CVCS	Check Valve, 2 1/2"/64mm CSA, Swivel CSA Female
D	70FL25CVNH	Check Valve, 2 1/2"/64mm NH, Swivel NH Female

- Installed on the discharge side of the pump to prevent pressure build-up in the pump and suction hose when the pump stops. Especially useful in up-hill pumping to prevent possible damage from return pressures



**PRIMER CHECK VALVE (POPPET)**

	Part#	Description
A	70FL15CVPNH	Primer / Poppet Check Valve - 1 1/2"/38mm NH (NST) Inlet & Outlet
A	70FL15CVPPFNM	Primer / Poppet Check Valve - 1 1/2"/38mm NPSH Female Inlet & 1 1/2"/38mm NH (NST) Outlet
A	70FL15CVPPS	Primer / Poppet Check Valve - 1 1/2"/38mm NPSH Inlet & Outlet
A	70FL15CVPBS	Primer / Poppet Check Valve - 1 1/2"/38mm BSP Inlet & Outlet
A	70FL15CVPQC	Primer / Poppet Check Valve - 1 1/2"/38mm NPSH Inlet & Forged QC Outlet
B	70FL15CVPSPNH	Primer / Poppet Check Valve .. 1"/25mm Female NPT side port, 1 1/2"/38mmNH swivel Female inlet x 1 1/2"/38mm NH (NST) Male outlet
B	70FL15CVPSPPS	Poppet Check Valve .. 1"/25mm Female NPT side port, 1 1/2"/38mmNPSH swivel Female inlet x 1 1/2"/38mm NPSH Male outlet
B	70FL15CVSPPPFNMN	Poppet Check Valve .. 1"/25mm Female NPT side port, 1 1/2"/38mmNPSH swivel Female inlet x 1 1/2"/38mm NH (NST) Male outlet

Additional threads available upon request, contact factory

- Designed for pumps with integral manual or exhaust priming requirements. This unit is engineered for maintenance free, simple, efficient and long life applications. The inlet is 1 1/2"/38mm NPSH and the outlet options are 1 1/2"/38mm NPSH, NST or QC connections
- The side port model consists of a 1"/25mm female NPT side port



## JERRY CAN (MILITARY STYLE)

- Durable, lightweight and rustproof, this tank is approved for air transport by rotary or fixed wing aircraft
- With the use of a fuel pick-up kit, the jerry can may be converted to a pump fuel tank and meets the rigid US Military and UN standards (certification # MIL-C-53 109)
- Registered by Transport Canada for UN performance packaging (certification # UN 3H 1/Y 1.0/200/yy/CAN/SPR 2-456/2.3mm)
- 5.3 US gals (4.4 IMP gals, 20L)

Part#	Description
70FLJER	Jerry Can Military Style (not available in the US)



OPTIONAL	
Part#	Description
70FLJER-FNKIT	Fuel Pick-up Kit .. with Male Chrysler fitting
70FLPFL-MC	Fuel line for Jerry Can, Female Mercury x Female Chrysler
70FLJERSPT	Flexible spout for Jerry Can



## JERRY CAN (USDA MODEL)

- Durable, lightweight and rustproof
- Internally self-venting and made from heavy-gauge steel by handcrafted manufacturing
- With the use of a fuel pick-up kit this Jerry can may be converted to a pump fuel tank
- Capacity 5 US gal / 20 Liters
- Meets USDA Specification 5100-274E

Part#	Description
70FLPFT5B-US DAN	Metal Fuel Tank (USDA model) 25 Liters / 6.6 US Gal.



OPTIONAL		
	Part#	Description
A	70FLPFT5B-GASKET	Cap Gasket for USDA fuel tank
B	70FLPFL-USDA	USDA pump fuel line
C	70FLPFL-MU	Pump fuel line, USDA Male, Mercury Female

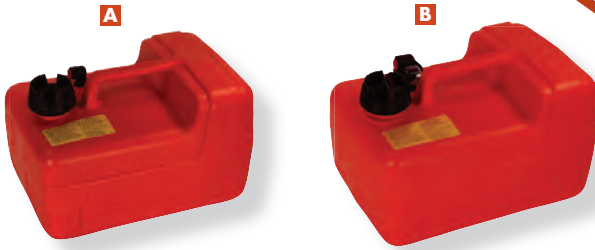

**PUMP FUEL TANK AND FUEL LINE**

	Part#	Description
A	70FLPFT2.5	Pump Fuel Tank 10 Liters / 2.6 U.S. Gallons
	70FLPFT2.5SAE	Pump Fuel Tank c/w SAE Male 10 Liters / 2.6 U.S. Gallons
B	70FLPFT3	Pump Fuel Tank 12 Liters / 3.2 U.S. Gallons with fuel gauge
C	70FLPFT5	Pump Fuel Tank 25 Liters / 6.6 U.S. Gallons

- Compact style tank, meets CSA Standards and is built for extensive use. Extremely durable and corrosion proof
- Available with several quick-connect fuel lines



**OPTIONAL**

	Part#	Description
A	70FLPFL	Fuel Line Complete (Chrysler)
A1	70FLPFL-CFS	Fuel Line Complete (USDA pump to Chrysler fuel tank)
A2	70FLPFL-SFC	Fuel Line Complete (Chrysler pump to USDA fuel tank)
B	70FLPFL-M	Fuel Line Complete (Mercury)
B	70FLPFL-MFS	Fuel Line Complete with Female Swivel (Mercury)
C	70FLPFL-Y	Fuel Line Complete (Yamaha)
D	70FLPFL-MAN	Fuel Line Complete Mercury Female (Manitoba)
N/I	70FLPFL-MAND	Dual Fuel Line Complete Mercury Female (Manitoba)
D1	70FLPFL-SASK	Fuel Line Complete Mercury Female (Saskatchewan)
N/I	70FLPFL-SASKD	Dual Fuel Line Complete Mercury Female (Saskatchewan)
E	70FLPFL-GSA	Fuel Line Complete with Female Swivel (GSA)
F	70FLPFL-NB	Fuel Line Complete with SAE swivel Female at both ends
G	70FLPFL-ADPMC	Fuel Line Adaptor Male Mercury to Female Chrysler
G1	70FLPFL-MDRN	Fuel Line drain .. Male Mercury
H	70FLPFLFV-M	Fuel Line Female Valve Fitting (Mercury)
H1	70FLPFLMV-MNL	Fuel Line Male valve fitting (Mercury)
H2	70FLPFL-ADPM	Remote fuel line Male valve fitting (Mercury)
H3	70FLPFL-ADPC	Remote fuel line Male valve fitting (Chrysler)
H4	70FLPFL-ADPM-SW	Base mounted fuel line Male valve fitting (Mercury)
I	70FLPFL-1185-3	Fuel Priming bulb 1/4"
J	72PW-FA355	Fuel tank Conversion Kit (FA355)
K	71W11-RFTKIT	Remote fuel kit for WICK 100M fire pump
L	70FLPFL-ADPMS	Fuel Line Adaptor Male Mercury to Female Chrysler with filter
N/I	78FBP0404FS	Fuel Line Fitting - 1/4" Barbed x 1/4" Swivel Female SAE
N/I	70FLPFT5-CAP	Cap / gauge for fuel tank
N/I	70FLPFT5-SPACK	Backpack Carrying Strap, for Pump fuel tank (70FLPFT5)

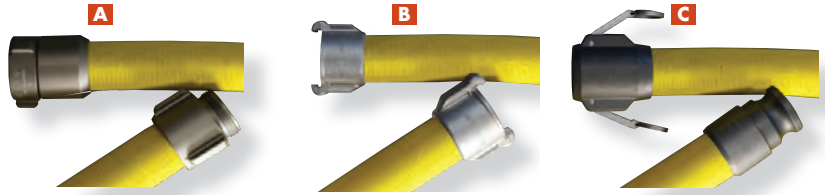

- Lightweight, 1 1/2" & 2" (38 & 51mm) diameter suction hose, polyurethane lined, non-collapsible, very kink resistant (see table below), heavy duty spun yarn construction with yellow Permatak HP™ treatment for higher abrasion resistance. Manufactured using the unique Mertex® method giving superior lining adhesion, and lower friction loss due to a smoother waterway.

Refer to our website for a complete listing and filtering tool .. [www.mercedestextiles.com](http://www.mercedestextiles.com)

## DRAFTLITE®

	Part#	Description
A	70FL15DLPS05	Draftlite HP suction hose .. 1 1/2"/38mm x 5'/1.5M c/w NPSH
A	70FL15DLPS08	Draftlite HP suction hose .. 1 1/2"/38mm x 8'/2.4M c/w NPSH
A	70FL15DLPS10	Draftlite HP suction hose .. 1 1/2"/38mm x 10'/3M c/w NPSH
A	70FL15DLNH05	Draftlite HP suction hose .. 1 1/2"/38mm x 5'/1.5M c/w NH
A	70FL15DLNH08	Draftlite HP suction hose .. 1 1/2"/38mm x 8'/2.4M c/w NH
A	70FL15DLNH10	Draftlite HP suction hose .. 1 1/2"/38mm x 10'/3M c/w NH
B	70FL15DLQC05	Draftlite HP suction hose .. 1 1/2"/38mm x 5'/1.5M c/w QC
B	70FL15DLQC08	Draftlite HP suction hose .. 1 1/2"/38mm x 8'/2.4M c/w QC
B	70FL15DLQC10	Draftlite HP suction hose .. 1 1/2"/38mm x 10'/3M c/w QC
A	70FL20DLNH05	Draftlite HP suction hose .. 2"/51mm x 5'/1.5M c/w NH
A	70FL20DLNH08	Draftlite HP suction hose .. 2"/51mm x 8'/2.4M c/w NH
A	70FL20DLNH10	Draftlite HP suction hose .. 2"/51mm x 10'/3M c/w NH
A	70FL20DLPS05	Draftlite HP suction hose .. 2"/51mm x 5'/1.5M c/w NPSH
A	70FL20DLPS08	Draftlite HP suction hose .. 2"/51mm x 8'/2.4M c/w NPSH
A	70FL20DLPS10	Draftlite HP suction hose .. 2"/51mm x 10'/3M c/w NPSH
C	70FL20DLCL05	Draftlite HP suction hose .. 2"/51mm x 5'/1.5M c/w Cam & Groove
C	70FL20DLCL08	Draftlite HP suction hose .. 2"/51mm x 8'/2.4M c/w Cam & Groove
C	70FL20DLCL10	Draftlite HP suction hose .. 2"/51mm x 10'/3M c/w Cam & Groove

Refer to our website for a complete listing and filtering tool .. [www.mercedestextiles.com](http://www.mercedestextiles.com)



- Low pressure suction hose
- Comes complete with choice of couplings as shown.

## SUCTION HOSE LP

	Part#	Description
A	70FL15SHNH8	Plastic Suction Hose 1 1/2"/38mm NH x 8'/2,4M
A	70FL15SHNH10	Plastic Suction Hose 1 1/2"/38mm NH x 10'/3,05M
A	70FL15SHPS10	Plastic Suction Hose 1 1/2"/38mm NPSH x 10'/3,05M
A	70FL15SHPS8	Plastic Suction Hose 1 1/2"/38mm NPSH x 8'/2,4M
B	70FL15SHQC10	Plastic Suction Hose 1 1/2"/38mm QC x 10'/3,05M
C	70FL15SHCL10	Plastic Suction Hose 1 1/2"/38mm QC x 10'/3,05M
D	70FL30SHRZ10	Plastic Suction Hose 3"/76mm x 10' (3,05M) .. Storz coupling
E	70FL30SHCL10	Plastic Suction Hose 3"/76mm x 10' (3,05M) .. Cam & Groove

Contact factory for other lengths and coupling options

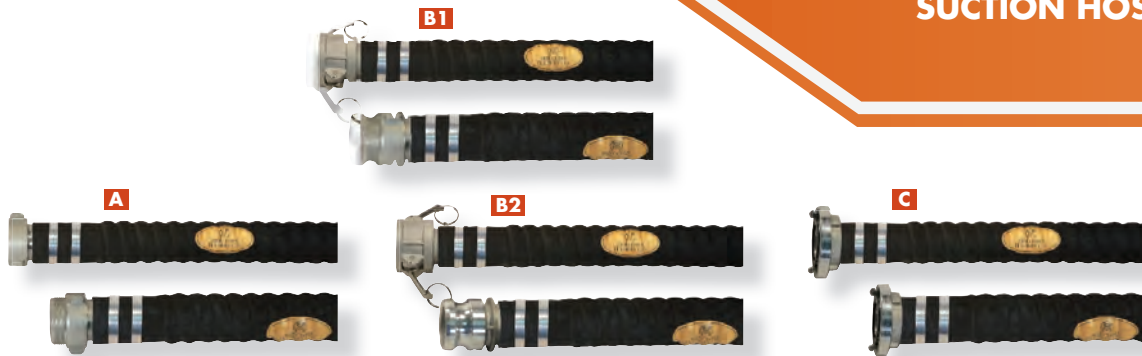

**SUCTION HOSE HP CRUSH RESISTANT**

	Part#	Description
A	70FL20SHPS08	HP Crush Resistant Suction Hose - 2"/51mm x 8'/2.4M c/w NPSH
A	70FL20SHPS10	HP Crush Resistant Suction Hose - 2"/51mm x 10'/3M c/w NPSH
B1	70FL20SHSP08	HP Crush Resistant Suction Hose - 2"/51mm x 8'/2.4M c/w Male NPSH by Female KAM/Lever
B2	70FL20SHCL10	HP Crush Resistant Suction Hose - 2"/51mm x 10'/3M c/w KAM/Lever
C	70FL20SHRZ10	HP Crush Resistant Suction Hose - 2"/51mm x 10'/3M c/w Storz

Contact factory for other lengths and coupling options

- A high quality, crush resistant, high pressure hose designed without the use of steel wire, for centrifugal pumps. It is capable of withstanding tandem pumping pressures without the use of a discharge side check valve. Extremely flexible for tight packaging without kinking. Easily coils to 30"/70cm. Designed for suction and pressure up to 550 PSI (38 Bar)

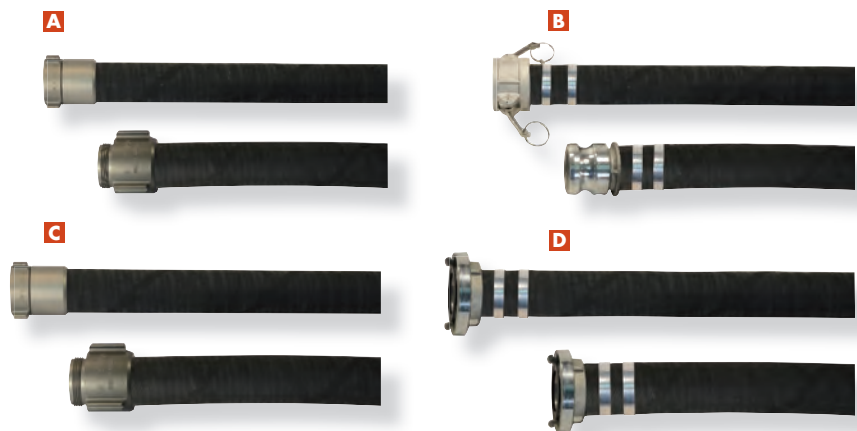

**SUCTION HOSE HP WIRE REINFORCED**

	Part#	Description
A	70FL15SHNH08-S	HP Wire Reinforced Suction Hose - 1 1/2"/38mm x 8'/2.4M NH
A	70FL15SHNH10-S	HP Wire Reinforced Suction Hose - 1 1/2"/38mm x 10'/3M NH
A	70FL15SHPS10-S	HP Wire Reinforced Suction Hose - 1 1/2"/38mm x 10'/3M NPSH
A	70FL20SHPS05-S	HP Wire Reinforced Suction Hose - 2"/51mm x 5'/1.5M NPSH
A	70FL20SHPS08-S	HP Wire Reinforced Suction Hose - 2"/51mm x 8'/2.4M NPSH
A	70FL20SHPS10-S	HP Wire Reinforced Suction Hose - 2"/51mm x 10'/3M NPSH
B	70FL20SHCL08-SS	HP Wire Reinforced Suction Hose - 2"/51mm x 8'/2.4M KAM/Lever Shank
B	70FL20SHCL10-SS	HP Wire Reinforced Suction Hose - 2"/51mm x 10'/3M KAM/Lever Shank
C	70FL20SHPS10-SS	HP Wire Reinforced Suction Hose - 2"/51mm x 10'/3M NPSH Shank
A	70FL25SHNH10	HP Wire Reinforced Suction Hose - 2 1/2"/64mm x 10'/3M 2 1/2"/64mm NH
D	70FL25SHRZ10	HP Wire Reinforced Suction Hose - 2 1/2"/64mm x 10'/3M 2 1/2"/64mm Storz

Contact factory for other lengths and coupling options

- A high quality, crush resistant, high pressure hose designed for centrifugal pumps. Made from smooth, weather and abrasion resistant rubber, with plies of polyester tire cord using helix wire. Designed for suction and pressure up to 550 PSI (38 Bar)



- A coupling set consists of a male, a female and one face gasket

### LONG SHANK COUPLING

Part#	Description
70FL20LSCPL	Long Shank coupling 2"/51mm NPSH (Set)
70FL20LSCPL-F	Long Shank coupling 2"/51mm Female NPSH
70FL20LSCPL-M	Long Shank coupling 2"/51mm Male NPSH
5232RZ32S	Long Shank coupling Alum Cast 2"/51mm Storz (1/2 set .. 2 required)
5240RZ40S	Long Shank coupling Alum Cast 2.5" Storz (1/2 set .. 2 required) .. fits 2 1/2"/64mm
78CLS3PRO	Long Shank coupling clamps
5932FGLS	Face Gasket Long Shank coupling 2"/51mm
6132PF32SVL	Swivel Nut for 2"/51mm Long Shank



- Will fit 2"/51mm or 2 1/2"/64mm suction hose

### STORZ SHANK COUPLING

Part#	Description
5232RZ32S	Long Shank coupling 2"/51mm Storz ( 1/2 set .. Requires 2)
5240RZ40S	Long Shank coupling 2 1/2"/64mm Storz ( 1/2 set .. Requires 2)



- 1 1/2"/38mm female NPSH low pressure plastic foot valve and strainer. Designed for flows up to 35 GPM US/132 LPM

### FOOT VALVE / STRAINER (PLASTIC MODEL)

Part#	Description
70FLV15-P	Foot Valve / Strainer (Plastic) 1 1/2" Female NPSH

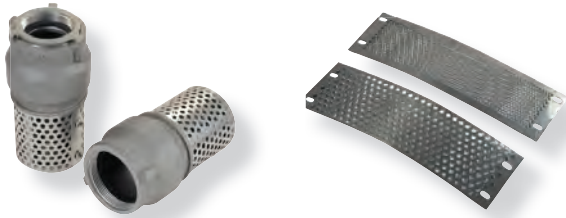

**FOOT VALVE 1 1/2"/38mm; 2"/51mm (STAINLESS STEEL STRAINER MODEL)**

Part#	Description
70FLV15NF	Foot Valve / Strainer 1 1/2"/38mm Female NH
70FLV15PF	Foot Valve / Strainer 1 1/2"/38mm Female NPSH
70FLV2BF	Foot Valve / Strainer 2"/51mm BSP Female
70FLV2PF	Foot Valve / Strainer 2"/51mm NPSH Female
70FLV2RZ	Foot Valve / Strainer 2"/51mm Storz
70FLV-1115S	Replacement Screen for 2"/51mm Foot Valve .. 5mm holes
70FLV-2774	Replacement Screen for 2"/51mm Foot Valve .. 2.5mm holes

- 1 1/2"/38mm or 2"/51mm female NPSH aluminum foot valve and strainer designed for use with high pressure centrifugal pumps. The check valve is spring loaded to ensure instantaneous closure, and also features an external pressure release. The strainer is made of stainless steel for long life. Designed for flows up to 100 GPM US / 378 LPM

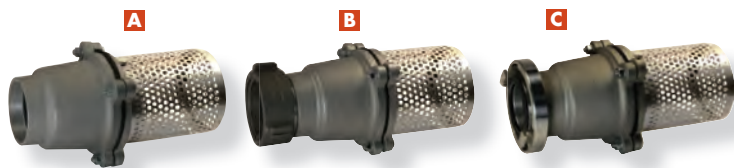

	Part#	Description
A	70FLV25BF-S	Foot Valve / Strainer 2 1/2"/64mm BSP Female (Stainless steel screen)
B	70FLV25NF-S	Foot Valve / Strainer 2 1/2"/64mm NH (NST) Female (Stainless steel screen)
B	70FLV25PF-S	Foot Valve / Strainer 2 1/2"/64mm NPSH Female (Stainless steel screen)
B	70FLV25MF-S	Foot Valve / Strainer 2 1/2"/64mm MER Female (Stainless steel screen)
B	70FLV25BAF-S	Foot Valve / Strainer 2 1/2"/64mm BAT Female (Stainless steel screen)
C	70FLV25RZ-S	Foot Valve / Strainer 2 1/2"/64mm Storz (Stainless steel screen)
	70FLV25-1115S	Replacement Stainless Steel Screen for 2 1/2"/64mm foot valve

Other threads available, contact factory

- Aluminum body construction, 2 1/2"/64mm model heavy duty foot valve and stainless steel strainer



**FOOT VALVE ADAPTORS**

Part#	Description
6124PF32PM	Foot Valve Adaptor 1 1/2"/38mm Female NPSH x 2" Male NPSH
6124NF32PM	Foot Valve Adaptor 1 1/2"/38mm Female NH x 2" Male NPSH
6140BM40NF	Foot Valve Adaptor, Rigid 2 1/2"/64mm BSP Male x 2 1/2"/64mm NH (NST) Female
6240BM40RZ	Foot Valve Adaptor, Rigid 2 1/2"/64mm BSP Male x 2 1/2"/64mm Storz

- Aluminum construction foot valve adaptors



## UNIQUE MERTEX® LINING PROCESS

A unique Mertex® process designed especially for the manufacturing of fire hose was developed exclusively by Mercedes Textiles Limited. This process uses a lining material in a molten state which is then introduced into the fabric jacket as it is being woven at the loom. No adhesives are used in this process. With this method, a smoother waterway is produced, yielding greater water flow at the discharge end. This continuous process is your assurance that Mercedes Fire Hose will provide the most efficient products available. Some advantages of our Mertex® process are:

- The superior liner adhesion of the Mertex® process allows for the use of high strength Filament Polyester yarn in both the warp & weft directions, for a greater burst safety margin
- Creates a virtually inseparable bond without the use of adhesives "NO DELAMINATION"
- Locks fibers together for even greater strength while still allowing for a high flexibility
- Creates an amazingly smooth waterway which yields an extremely low friction (pressure) loss "HIGHER FLOW"
- Produces lower elongation under pressure. Lower elongation means less back pull when water is suddenly shut-off, resulting in a safer hose to work with in firefighting
- Permits manufacturing to any length (Call factory for non-standard lengths)

HOSE LOOM WITH "EXTRUDER"  
EXPERIENCE UP TO 66% GREATER FLOW

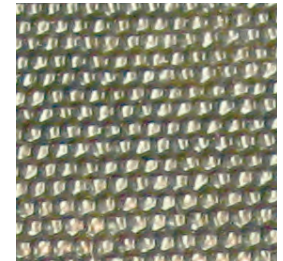
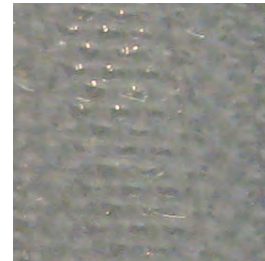
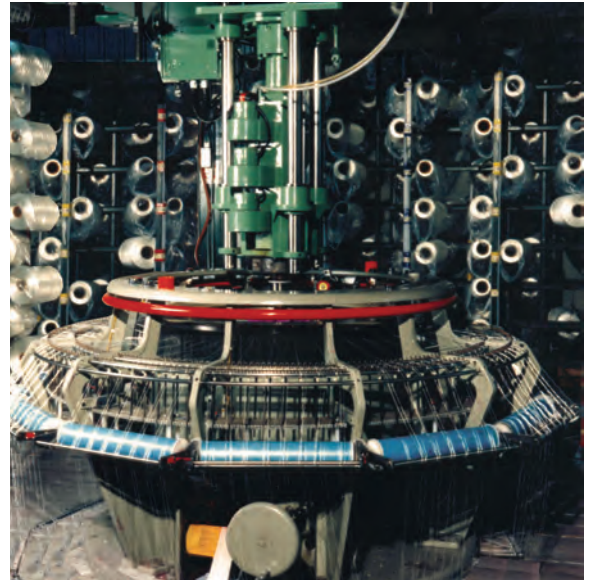

Our Mertex® Process Synthetic  
Hose Lining (smooth surface  
= less friction/greater flow)

Example: Competitor's Synthetic  
hose lining (rough surface  
= less flow)

## PERMATEK HP™ TREATMENT FOR HOSE JACKETS

Permatek HP™ treatment is a high performance polymeric dispersion which saturates each and every fiber of the hose jacket, ensuring superior physical properties. Some of the advantages of the Permatek HP™ treatment are:

- Locks all fibers together for greater strength
- Produces a lower drag coefficient in charged hose lays which results in greater ease of advancement
- Reduces water pickup and absorption
- Provides excellent protection against abrasion
- Provides resistance to petroleum products, hydrocarbons, most solvents and greases
- Excellent resistance against UV and Ozone
- Results in much shorter drying time

PERMATEK HP™ TREATMENT IS AVAILABLE  
IN THE 9 NFPA COLORS



Note: Actual hose colors may vary from the colors shown in this catalogue



## Hydro-Wick® PROCESS

### UNIQUE HYDRO-WICK® WEEPING PROCESS

Special problems require special solutions and Mercedes Textiles Limited is particularly innovative in creating practical solutions to difficult problems. When the Forest Services of North America needed a more finely controlled weeping (self-protecting) hose than the previous technology could provide, Mercedes Textiles created this clever yet simple design wherein carefully spaced yarns were exposed into the waterway. Through capillary action, a controlled amount of water is allowed to WICK through the yarn and quickly soak the jacket thoroughly. This action produces a wetted outer surface without reducing flow or creating additional turbulence. When the jacket is fully wet, the capillary action automatically stabilizes.

- The Hydro-Wick® weeping process results in considerably less pressure loss than competing products, while still maintaining protection against fire and heat
- Virtually eliminates clogging, as compared to competing products
- Complete wet out is achieved in up to 300% less time than the needle prick method
- The resulting wet jacket provides excellent protection against heat, i.e., forest fire applications

### HYDRO-WICK® WEEPING PROCESS “WICK EFFECT”

#### LINER WICKS PICK UP THE WATER

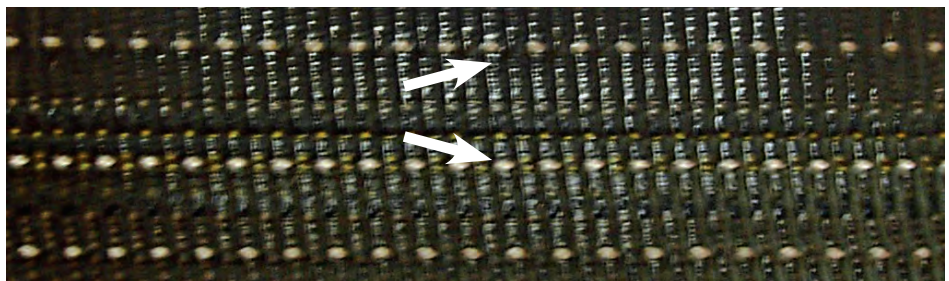

#### JACKET WICKS DISTRIBUTE THE WATER

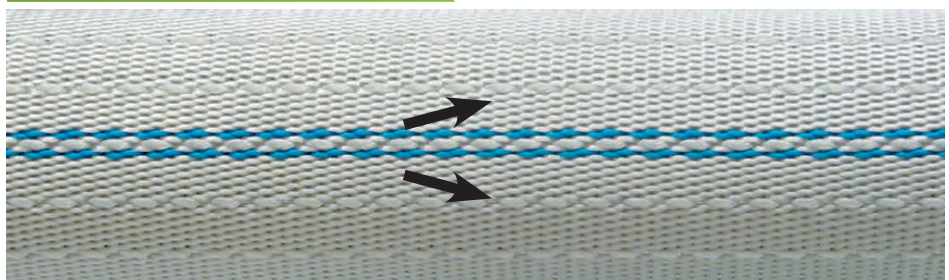



# FIREBREAK II®

Worldwide, the #1 choice for weeping hose among forest fire agencies.

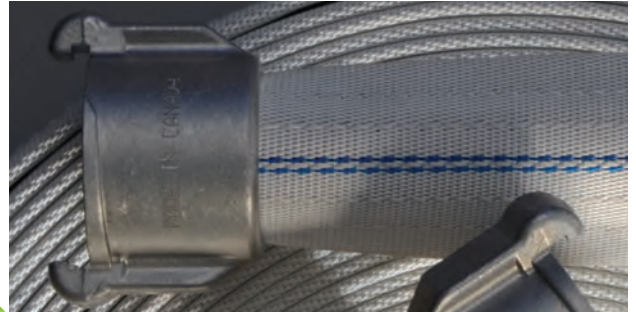

### Applications

- Forestry light weight, self-protecting, attack / supply hose
- Urban interface, grass fire kits, and mop up hose
- Wildland brush fire truck attack hose
- Cottage and forestry home values protection hose

### Features and Benefits

- Unique Hydro-Wick® weeping process producing a “wick” effect to dampen the hose jacket
- Tough and light in weight
- Unique Mertex® lining
- Premium all synthetic single jacket
- Resistant to most chemicals, petrol products, ozone and U.V. exposure, hydrolysis, rot and mildew
- Remains flexible to -65° F (-55° C)
- Meets or exceeds all performance requirements of NFPA 1961, Underwriters Laboratories and Factory Mutual
- Meets ULC requirements S519.1 and can be labeled upon request in the sizes\* specified below

Hose Spec	Trade Size		Bowl Size		Weight Un-coupled 100'(30.5M)		Coil Diameter 100'(30.5M)		Service Pressure		Proof Pressure		Burst Pressure	
	In.	mm	In	mm	LBS	Kg	In.	Cm.	PSI	kPa	PSI	kPa	PSI	kPa
730	1.00	25	1 5/32	29	8.0	3.6	14.0	35.6	300	2 070	600	4 140	900	6 200
731	1.5*	38*	1 11/16	43	11.0	5.0	14.0	35.6	300	2 070	600	4 140	1 000	6 900
734	2.50	64	2 11/16	68	16.5	7.5	15.0	38.1	250	1 725	500	3 450	800	5 515

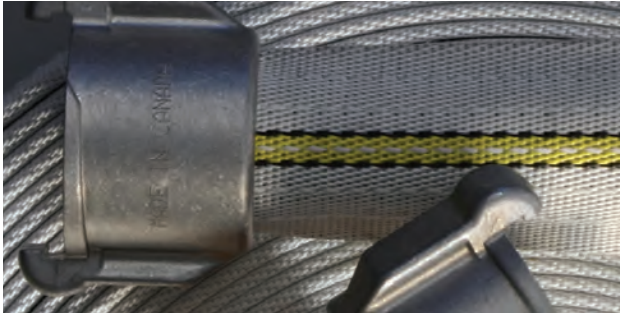

## PERCOLITE™

All synthetic ULC weeping hose approved for helicopter deployment, where every pound matters.

### Applications

- Helicopter attack hose
- Forestry extra light weight, self-protecting, attack hose
- Urban interface, grass fire kits, and mop up hose
- Cottage and forestry home values protection hose

- Unique Mertex® lining
- Premium all synthetic single jacket
- Resistant to most chemicals, petrol products, ozone and U.V. exposure, hydrolysis, rot and mildew
- Meets ULC requirements and can be labeled upon request in the sizes\* specified below

### Features and Benefits

- Extremely light in weight
- Unique Hydro-Wick® weeping process producing a "wick" effect to dampen the hose jacket

Hose Spec	Trade Size		Bowl Size		Weight Un-coupled 100'(30.5M)		Coil Diameter 100'(30.5M)		Service Pressure		Proof Pressure		Burst Pressure	
	In.	mm	In.	mm	LBS	Kg	In.	Cm.	PSI	kPa	PSI	kPa	PSI	kPa
710	1.00	25	1 5/32	29	6.6	3.0	14.0	35.6	300	2 070	600	4 140	900	6 200
711	1.5*	38*	1 11/16	43	9.0	4.1	14.0	35.6	300	2 070	600	4 140	900	6 200

Available Colors



## FIREBOSS®

Most rugged with lowest friction loss, all synthetic non-percolating forestry hose, standard with yellow Permatek HP™ treatment.

### Applications

- Forestry and industrial applications hose
- Wildland brush fire truck attack hose
- Cottage and forestry home values protection hose

- Premium all synthetic single jacket
- Resistant to most chemicals, petrol products, ozone and U.V. exposure, hydrolysis, rot and mildew
- Meets or exceeds all performance requirements of NFPA 1961, Underwriters Laboratories and Factory Mutual
- Meets or exceed all performance requirements of U.S.D.A. spec 5100-187C Type II for 1" (25mm) and 1 1/2" (38mm)

### Features and Benefits

- Tough and ready for action and light in weight.
- Spun yarn jacket for superior abrasion resistance
- Standard strobe yellow Permatek HP™ treatment against abrasion, moisture pick up and mildew
- Unique Mertex® lining

Hose Spec	Trade Size		Bowl Size		Weight Un-coupled 100'(30.5M)		Coil Diameter 100'(30.5M)		Service Pressure		Proof Pressure		Burst Pressure	
	In.	mm	In.	mm	LBS	Kg	In.	Cm.	PSI	kPa	PSI	kPa	PSI	kPa
750	1.00	25	1 5/32	29	9.0	4.1	17.0	43.2	300	2 070	600	4 140	1 000	6 900
751	1.50	38	1 11/16	43	13.5	6.1	17.0	43.2	300	2 070	600	4 140	1 000	6 900
752	1.75	44	1 7/8	48	15.5	7.0	17.0	43.2	300	2 070	600	4 140	1 000	6 900



## FIRE STOP®

A rugged all synthetic non-percolating forestry hose.

### Applications

- Forestry and industrial applications hose
- Wildland brush fire truck attack hose
- Cottage and forestry home values protection hose

### Features and Benefits

- Tough and ready for action and light in weight
- Spun yarn jacket for superior abrasion resistance
- Unique Mertex® lining
- Premium all synthetic single jacket

- Available with Permatek HP™ treatment against abrasion, moisture pick up and mildew
- Resistant to most chemicals, petrol products, ozone and U.V. exposure, hydrolysis, rot and mildew
- Meets or exceeds all performance requirements of NFPA 1961, Underwriters Laboratories and Factory Mutual
- Meets or exceed all performance requirements of U.S.D.A. spec 5100-187C Type II for 1" (25mm) and 1 1/2" (38mm), when coated

Available Colors



Hose Spec	Trade Size		Bowl Size		Weight Un-coupled 100'(30.5M)		Coil Diameter 100'(30.5M)		Service Pressure		Proof Pressure		Burst Pressure	
	In.	mm	In.	mm	LBS	Kg	In.	Cm.	PSI	kPa	PSI	kPa	PSI	kPa
740	1.00	25	1 5/32	29	8.6	3.9	16.0	40.6	300	2 070	600	4 140	1 000	6 900
741	1.50	38	1 11/16	43	13.0	5.9	16.0	40.6	300	2 070	600	4 140	1 000	6 900
742	1.75	44	1 7/8	48	14.8	6.7	16.0	40.6	300	2 070	600	4 140	1 000	6 900

Available Colors



## FORESTGUARD II®

Tough, all synthetic, ULC approved non-percolating forestry hose.

### Applications

- Forestry lightweight, attack /supply hose
- Urban interface, grass fire kits, and mop up hose
- Wildland brush fire truck attack hose
- Cottage and forestry home values protection hose

### Features and Benefits

- A tough versatile lightweight forestry fire hose
- Unique Mertex® lining
- Premium all synthetic single jacket

- Available with Permatek HP™ treatment against abrasion, moisture pick up and mildew
- Resistant to most chemicals, petrol products, ozone and U.V. exposure, hydrolysis, rot and mildew
- Remains flexible to -65° F (-55° C)
- Meets or exceeds all performance requirements of NFPA 1961, Underwriters' Laboratories of Canada Spec S518.1, Factory Mutual and USDA Spec 5100-187C Type I for 1" (25mm) and 1 1/2" (38mm) when treated yellow.
- Meets ULC requirements and can be labeled upon request in the sizes\* specified below

Hose Spec	Trade Size		Bowl Size		Weight Un-coupled 100'(30.5M)		Coil Diameter 100'(30.5M)		Service Pressure		Proof Pressure		Burst Pressure	
	In.	mm	In.	mm	LBS	Kg	In.	Cm.	PSI	kPa	PSI	kPa	PSI	kPa
704	1.00	25	1 5/32	29	8.0	3.6	14.0	35.6	300	2 070	600	4 140	1 000	6 900
705	1.5*	38*	1 11/16	43	11.8	5.4	14.0	35.6	300	2 070	600	4 140	1 000	6 900
706	1.75	44	1 7/8	48	13.5	6.1	15.0	38.1	300	2 070	600	4 140	900	6 200
701	2.50	64	2 3/4	70	22.0	10.0	16.5	41.9	300	2 070	600	4 140	900	6 200



Available Colors

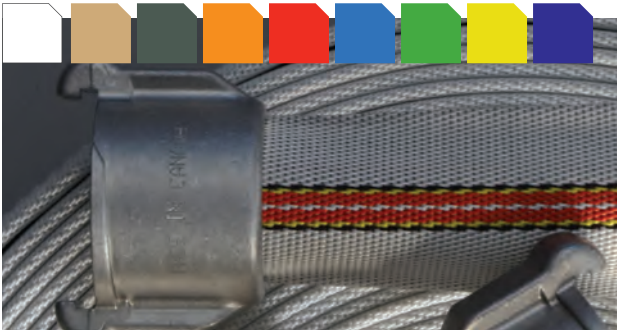

## FORESTSTREAM<sup>®</sup>

A light weight all synthetic, non-percolating, ULC approved forestry hose for both helicopter deployment and over-land supply.

### Applications

- Forestry extra lightweight, attack /supply hose
- Helicopter attack hose
- Urban interface, grass fire kits, and mop up hose
- Cottage and forestry home values protection hose

### Features and Benefits

- Extremely light in weight
- Unique Mertex<sup>®</sup> lining
- Premium all synthetic single jacket

- Available with Permatak HP<sup>™</sup> treatment against abrasion, moisture pick up and mildew
- Resistant to most chemicals, petrol products, ozone and U.V. exposure, hydrolysis, rot and mildew
- Remains flexible to -65° F (-55° C)
- Meets or exceeds all performance requirements of NFPA 1961, Underwriters' Laboratories of Canada Spec S518.1, Factory Mutual and USDA Spec 5100-187C Type I, for 1"(25mm) and 1 1/2"(38mm)
- Meets ULC requirements and can be labeled upon request in the sizes\* specified below

Hose Spec	Trade Size		Bowl Size		Weight Un-coupled 100'(30.5M)		Coil Diameter 100'(30.5M)		Service Pressure		Proof Pressure		Burst Pressure	
	In.	mm	In.	mm	LBS	Kg	In.	Cm.	PSI	kPa	PSI	kPa	PSI	kPa
713	1.00	25	1 5/32	29	6.5	3.0	13.5	34.3	300	2 070	600	4 140	900	6 200
715	1.5*	38*	1 11/16	43	9.5	4.3	13.5	34.3	300	2 070	600	4 140	900	6 200
718	2.50	64	2 11/16	68	16.5	7.5	15.0	38.1	250	1 725	500	3 450	750	5 175

Available Colors



## MTS-187 T-2<sup>™</sup>

Rugged all synthetic, single jacket forestry hose, c/w our yellow Permatak<sup>™</sup> HP treatment and our "lowest friction loss" lining.

### Applications

- Wildland Brush Fire Truck Attack Hose
- Industrial and Forestry Applications Hose
- Cottage and forestry home values protection hose

### Features and Benefits

- Tough and ready for action but light in weight
- Our unique Mertex<sup>®</sup> lining process produces an amazingly thin but smooth inner waterway, yielding an extremely low friction loss for maximum flow
- Standard Strobe Yellow Permatak<sup>™</sup> HP treatment for greater

- visibility & abrasion resistance and greatly reduces moisture absorption through the jacket
- Resistant to most chemicals, petrol products, ozone & U.V. exposure, hydrolysis, and rot & mildew Meets or exceeds all performance requirements of NFPA 1961, Underwriter's Laboratories & Factory Mutual
- Meets or exceed all performance requirements of U.S.D.A. spec 5100-187B Type II

Hose Spec	Trade Size		Bowl Size		Weight Un-coupled 100'(30.5M)		Coil Diameter 100'(30.5M)		Service Pressure		Proof Pressure		Burst Pressure	
	In.	mm	In.	mm	LBS	Kg	In.	Cm.	PSI	kPa	PSI	kPa	PSI	kPa
535	1.00	25	1 5/32	29	8.8	4.0	16.0	40.6	300	2 070	600	4 140	900	6 200
536	1.50	38	1 11/16	43	11.8	5.4	16.5	41.9	300	2 070	600	4 140	900	6 200
537	1.75	44	1 7/8	48	14.2	6.5	16.5	41.9	300	2 070	600	4 140	900	6 200



## MYTI-FLO®

A circular woven, seamless, all synthetic hose featuring "lowest friction loss lining."

Available Colors



### Applications

- Forestry mop-up and sprinkler hose
- Cottage and forestry home values protection hose
- Decontamination and wash down hose
- Industrial applications hose
- Marine fire hose and RV potable water (when specified)

- Unique Mertex® lining
- Premium all synthetic single jacket
- Available with Permatak HP™ treatment against abrasion, moisture pick up and mildew
- Resistant to most chemicals, petrol products, ozone and U.V. exposure, hydrolysis, rot and mildew
- Remains flexible to -65° F (-55° C)
- Meets or exceeds all performance requirements of NFPA 1961, Underwriters Laboratories and Factory Mutual
- Available with both GHT and Baby Merlug® 3/4"/19mm QC couplings

### Features and Benefits

- Seamless, light weight, and multipurpose

Hose Spec	Trade Size		Bowl Size		Weight Un-coupled 50'(15.2M)		Coil Diameter 50'(15.2M)		Service Pressure		Proof Pressure		Burst Pressure	
	In.	mm	In.	mm	LBS	Kg	In.	Cm.	PSI	kPa	PSI	kPa	PSI	kPa
810	5/8	16	N/A	N/A	1.5	0.7	8.0	20.3	250	1 725	500	3 450	750	5 175
719	3/4	19	N/A	N/A	1.7	0.8	8.0	20.3	250	1 725	500	3 450	750	5 175

Available Colors



## BOOSTLITE®

A non-collapsible reel hose designed to meet a variety of fire attack requirements.

### Applications

- Booster reel hose
- Range control attack hose
- Wildland brush fire truck attack hose
- Compressed Air Foam System (CAFS) applications

- Non-Collapsible and fits standard hose reels
- Heavy duty spun yarn construction
- Unique Mertex® lining
- Premium all synthetic single jacket
- Standard Strobe Yellow Permatak HP™ treatment against abrasion, moisture pick up and mildew
- Resistant to most chemicals, petrol products, ozone and U.V. exposure, and hydrolysis
- Temperature range of -60° F to 160° F (-50° C to 71° C)
- Available with expansion ring and field repairable couplings, field repairable splice, factory installed compression splice and compression couplings
- Also available in 1 1/4" / 32mm upon special request

### Features and Benefits

- Extremely kink resistant, even at low pressure
- Bend radius is less than 3 1/2"/8.9cm for a 3/4"/19mm hose; 4 1/2"/11.4cm for a 1.0"/25mm hose; and 9.0"/23cm for a 1 1/2"/38mm hose

Hose Spec	Trade Size		Bowl Size		Weight Un-coupled 100'(30.5M)		Coil Diameter 100'(30.5M)		Service Pressure		Proof Pressure		Burst Pressure	
	In.	mm	In.	mm	LBS	Kg	In.	Cm.	PSI	kPa	PSI	kPa	PSI	kPa
799	0.75	19	1 1/16	27	14.9	6.8	15.3	38.9	400	2 755	800	5 515	2 000	13 775
800	1.00	25	1 9/32	33	19.3	8.8	18.0	45.7	400	2 755	800	5 515	2 000	13 775
801	1.50	38	1 13/16	46	32.0	14.5	25.0	63.5	400	2 755	800	5 515	1 800	12 400



Available Colors

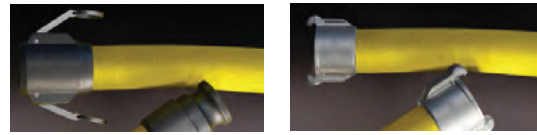
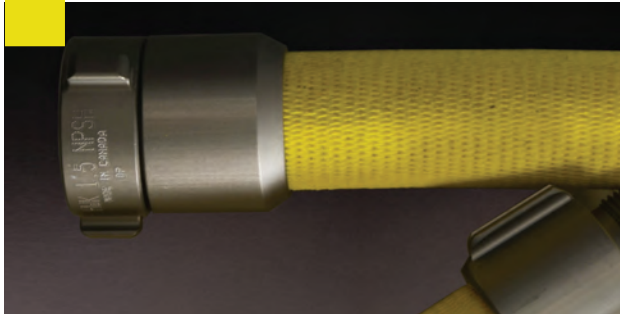

## DRAFTLITE®

A crush resistant draft hose where light weight and high pressure resistance are critical.

### Applications

- Suction /Supply Line

### Features and Benefits

- Extremely kink resistant - See table for bend radius
- Heavy duty spun yarn construction
- Ideal for helicopter applications
- Unique Mertex® lining
- Premium all synthetic single jacket
- Standard Strobe Yellow Permatek HP™ treatment against abrasion, moisture pick up and mildew
- Resistant to most chemicals, petrol products, ozone and U.V. exposure, hydrolysis, rot and mildew
- Temperature range of -60° F to 160° F (-50° C to 71° C)
- Available with NH, NPSH, QC and Cam and Groove couplings

Hose Spec	Trade Size		Bowl Size		Weight Coupled 10'(3M)		Bend Radius		Service Pressure		Proof Pressure		Burst Pressure	
	In.	mm	In	mm	LBS	Kg	In.	Cm.	PSI	kPa	PSI	kPa	PSI	kPa
802	1.50	38	1 13/16	46	4.6	2.1	12.5	32	400	2 755	800	5 515	1 200	8 275
803	2.00	51	2 5/16	59	5.5	2.5	15.0	38	400	2 755	800	5 515	1 200	8 275



## QUICKCONNECT®

The only End to End Quick Connect (1/4 turn) System From 3/4" (19mm) through to 2 1/2" (63mm).

### APPLICATIONS

- Forestry, industrial and municipal hose

### FEATURES AND BENEFITS

- The only sexless system to offer a full flow waterway
- Rapid connect and disconnect equals faster firefighting
- No threads or swivel to damage
- Compatibility among fire agencies
- Can attach hose sizes from 3/4" to 2 1/2" (3/4" (19mm to 63mm)
- Hose can be rolled from either end
- High strength, forged couplings allow for multiple re-use
- Extended Merlug® facilitates universal spanner wrenches
- Babylug™ is the only quick connect coupling in the industry for 5/8" and 3/4" (16mm and 19mm) forestry hose
- ULC and USDA approved for 1" and 1 1/2" (25mm and 38mm)
- Field proven for over 20 years



For insertion along a hose line to extract water for various uses (Feeding smaller hoses for fire fighting, sprinklers, filling tanks, etc).



**WATER THIEF AND HOSE LINE "T"**

	Part#	Description
A	70FL15WTNH	Water Thief 1 1/2"/38mm c/w NH (NST)
A	70FL15WTPS	Water Thief 1 1/2"/38mm c/w NPSH
A1	70FL15WTQC	Water Thief 1 1/2"/38mm c/w ULC Forged QC
A1 + B	70FL15WTQC-H	Water Thief 1 1/2"/38mm c/w ULC Forged Adaptors & 5' (1.5M) Filler Hose
A2	70FL15WTBM	Water Thief 1 1/2"/38mm c/w BSP (Male - Male)
N/1	70FL15WTQDC	Water Thief 1 1/2"/38mm c/w Die-Cast QC
C	70FLT15NH10PS	Hose Line "T" .. 1 1/2"/38mm NH x 1" NPSH male (No Cap & Chain)
C	70FLT15PS10PS	Hose Line "T" .. 1 1/2"/38mm NPSH x 1" NPSH male (No Cap & Chain)
C1	70FLT15NH10PS-C	Hose Line "T" .. 1 1/2"/38mm NH x 1" NPSH male (with Cap & Chain)
C1	70FLT15PS10PS-C	Hose Line "T" .. 1 1/2"/38mm NPSH x 1" NPSH male (with Cap & Chain)
C2	70FLT15QC10PS	Hose Line "T" .. 1 1/2"/38mm QC x 1" NPSH male (No Cap & Chain)
C3	70FLT15QC10PS-C	Hose Line "T" .. 1 1/2"/38mm QC x 1" NPSH male (with Cap & Chain)
C4	70FLT15ONH07GH-C	Hose Line "T" .. 1"/25mm NH Fem x 1"/25mm NH Male x 3/4"GHTM, Cap & Chain
C4	70FLT15OPS10PS-C	Hose Line "T" .. 1"/25mm NPSH Fem x 1"/25mm NPSH Male x 1"/25 NPSH Male, Cap & Chain
C4	70FLT15ONH10NH-C	Hose Line "T" .. 1"/25mm NH Fem x 1"/25mm NH Male x 1"/25mm NH Male, Cap & Chain
D	70FL25WTBA15PM	Water Thief 2 1/2"/64mm AMA/BCT x 1 1/2" NPSH Male (No Valve)
D	70FL25WTCS15PM	Water Thief 2 1/2"/64mm CSA x 1 1/2"/38mm NPSH Male (No Valve)
D	70FL25WTME15PM	Water Thief 2 1/2"/64mm MER (N.S.) x 1 1/2" NPSH Male (No Valve)
D	70FL25WTNH15PM	Water Thief 2 1/2"/64mm NH x 1 1/2"/38mm NPSH Male
D	70FL25WTWC15PM	Water Thief 2 1/2" WCT x 1 1/2" NPSH Male (No Valve)
D1	70FL25WTCS15QC	Water Thief 2 1/2"/64mm CSA x 1 1/2"/38mm Forged QC (No Valve)
D1	70FL25WTNH15QC	Water Thief 2 1/2"/64mm NH x 1 1/2"/38mm QC
D2	70FL25WTQC15PM	Water Thief 2 1/2"/64mm QC x 1 1/2"/38mm NPSH Male
D3	70FL25WTQC15QC	Water Thief 2 1/2"/64mm QC x 1 1/2"/38mm QC
N/1	70FL15WTVL	Water Thief Replacement Valve (less GHT fitting)
N/1	6406TM12GM	Male GHT fitting for Water Thief Replacement Valve

Required to split a hose line into 3 lines. It is machined from aluminum alloy, will withstand tandem pressures and is corrosive resistant.



**3 WAY COLLECTING HEAD**

	Part#	Description
A	70FL15PY3PM	3 Way Collecting Head 1 1/2"/38mm Male NPSH
B	70FL15PY3QC	3 Way Collecting Head 1 1/2"/38mm Forged QC
C	70FL15PY3SW	3 Way Collecting Head 1 1/2"/38mm Sweden

Controls the water flow to either one or to both of two parallel lines.



**3 WAY DIVERTER VALVE**

	Part#	Description
A	70FL3WV15PS	3 Way diverter valve 1 1/2"/38mm NPSH
A	70FL3WV15BS	3 Way diverter valve 1 1/2"/38mm BSP
B	70FL3WV15QC	3 Way diverter valve 1 1/2"/38mm QC
C	70FL3WV20PS	3 Way diverter valve 2"/51mm NPSH



WYE

	Part#	Description
A	6412GF12GMY	Plain Wye - 3/4"/19mm GHT Female to 3/4"/19mm GHT Male
B	70FL15PYNH	Plain Wye - 1 1/2"/38mm NH (NST)
B	70FL15PYPS	Plain Wye - 1 1/2"/38mm NPSH
B	70FL15PYBS	Plain Wye - 1 1/2"/38mm BSP
C	70FL15PYSW	Plain Wye - 1 1/2"/38mm Sweden
D	70FL15PYQC	Plain Wye - 1 1/2"/38mm Forged QC
E	70FL25PYNH	Plain Wye - 2 1/2"/64mm NH (NST)

Required to split a hose line into two lines.



GATED WYE

	Part#	Description
A	70FL25GYQC	- 2 1/2" QC x 2 1/2" QC
B	70FL25GYBA15PS	Gated Wye - 2 1/2"/64mm Female BCT/AMA by two 1 1/2"/38mm Male NPSH
B	70FL25GYCS15PS	Gated Wye - 2 1/2"/64mm Female CSA by two 1 1/2"/38mm Male NPSH
B	70FL25GYME15PS	Gated Wye - 2 1/2"/64mm Female N. Scotia Zone 1 by two 1 1/2"/38mm Male NPSH
B	70FL25GYNH15NH	Gated Wye - 2 1/2"/64mm Female NH (NST) by two 1 1/2"/38mm Male NH (NST)
B	70FL25GYNH15PS	Gated Wye - 2 1/2"/64mm Female NH (NST) by two 1 1/2"/38mm Male NPSH
B	70FL25GYQS15PS	Gated Wye - 2 1/2"/64mm Female QST by two 1 1/2"/38mm Male NPSH
B	70FL25GYWC15PS	Gated Wye - 2 1/2"/64mm Female WCT by two 1 1/2"/38mm Male NPSH
C	70FL25GYNH10NH	Gated Wye - 2 1/2" Female NH by two 1" Male NH
D	70FL25GYQC15QC	Gated Wye - 2 1/2"/64mm QC by two 1 1/2"/38mm QC
E	70FL25GYCS15QC	Gated Wye - 2 1/2"/64mm Female CSA by two 1 1/2"/38mm QC
E	70FL25GYWC15QC	Gated Wye - 2 1/2"/64mm Female WCT by two 1 1/2"/38mm QC
F	70FL15GYBS	Gated Wye - 1 1/2"/38mm Female BSP by two 1 1/2"/38mm Male BSP
F	70FL15GYNH	Gated Wye - 1 1/2"/38mm Female NH (NST) by two 1 1/2"/38mm Male NH (NST)
F	70FL15GYPS	Gated Wye - 1 1/2"/38mm Female NPSH by two 1 1/2"/38mm Male NPSH
G	70FL15GYPS10PS	Gated Wye - 1 1/2"/38mm Female NPSH by two 1" Male NPSH
G	70FL15GYNH10NH	Gated Wye - 1 1/2"/38mm Female NH (NST) by two 1"/25mm Male NH (NST)
G	70FL15GYNH10PS	Gated Wye - 1 1/2"/38mm Female NH (NST) by two 1"/25mm Male NPSH
H	70FL10GYBS	Gated Wye - 1"/25mm Female BSP by two 1"/25mm Male BSP
H	70FL10GYNH	Gated Wye - 1"/25mm Female NH (NST) by two 1"/25mm Male NH (NST)
H	70FL10GYPS	Gated Wye - 1"/25mm Female NPSH by two 1"/25mm Male NPSH
I	70FL15GYQC	Gated Wye - 1 1/2"/38mm Forged QC
J	6412GF12GMY	Gated Wye - 3/4"/19mm GHT Female by two 3/4" GHT Male

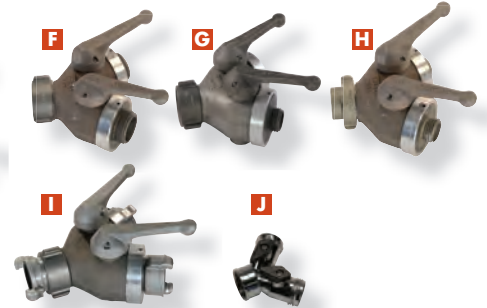

Permits complete flow control when a hose line needs to be split into two lines, when two lines are combined into one hose line, or when feed line is shut off.

Contact factory for other available combinations



SHUT-OFF VALVE

	Part#	Description
A	70FL15S010PFPF	Shut-off valve 1" NPSH Female x 1" NPSH Female
B	70FL15S010PF15PF	Shut-off valve 1" NPSH Female x 1 1/2" NPSH Female
B	70FL15S010PF15NF	Shut-off valve 1" NPSH Female x 1 1/2" NH Female
C	70FL15S015NFM	Shut-off valve 1 1/2" NH Male x 1 1/2" NH Female
C	70FL15S015PFPM	Shut-off valve 1 1/2" NPSH Male x 1 1/2" NPSH Female
D	70FL15S015PFQC	Shut-off valve 1 1/2" NPSH Female x 1 1/2" QC

Controls the water flow in a single hose line.



Rugged construction and available in nominal flow rate:

- 1" produces up to 22 US gpm (83 lpm)
- 1 1/2" produces up to 75 US gpm (284 lpm)

**Blue (E) Models**

The blue (E) models are same as the red models, except that there is no straight stream and it opens on a 30 degree fog pattern. Designed for use on electric equipment and switching panels.



**NOZZLE .. FOG / STRAIGHT STREAM**

	Part#	Description
A	70FL10ZFGBS	Nozzle .. Fog / Straight Stream 1"/25mm c/w BSP
A	70FL10ZFGNH	Nozzle .. Fog / Straight Stream 1"/25mm c/w NH (NST)
A	70FL10ZFGPS	Nozzle .. Fog / Straight Stream 1"/25mm c/w NPSH
A	70FL10ZFGQC	Nozzle .. Fog / Straight Stream 1"/25mm c/w Forged QC
A	70FL15ZFGNH	Nozzle .. Fog / Straight Stream 1 1/2"/38mm c/w NH (NST)
A	70FL15ZFGPS	Nozzle .. Fog / Straight Stream 1 1/2"/38mm c/w NPSH
A	70FL15ZFGQC	Nozzle .. Fog / Straight Stream 1 1/2"/38mm c/w Forged QC
A	70FL15ZFGQDC	Nozzle .. Fog / Straight Stream 1 1/2"/38mm c/w Die Cast QC
B	70FL15ZFGPS-EB	Nozzle .. Fog only 1 1/2"/38mm c/w NPSH (Blue)
B	70FL15ZFGQC-EB	Nozzle .. Fog only 1 1/2"/38mm c/w QC (Blue)

A compact aluminum nozzle with an integral shut-off and orifices of :

- 1/8", 3/16"; 1/4"; 5/16"
- (3mm; 4.7mm; 6.3mm; 8mm)



**NOZZLE .. MULTI-ORIFICE**

	Part#	Description
A	70FL10ZMONH	Nozzle .. Multi-Orifice - 1.0"/25mm NH (NST)
A	70FL10ZMOPS	Nozzle .. Multi-Orifice - 1.0"/25mm NPSH
A	70FL15ZMONNH	Nozzle .. Multi-Orifice - 1 1/2"/38mm NH (NST)
A	70FL15ZMONPS	Nozzle .. Multi-Orifice - 1 1/2"/38mm NPSH
A	70FL15ZMONBS	Nozzle .. Multi-Orifice - 1 1/2"/38mm BSP
B	70FL15ZMONQC	Nozzle .. Multi-Orifice - 1 1/2"/38mm Quick Connect
C	70FL15ZMONSWA	Nozzle .. Multi-Orifice - 1 1/2"/38mm Sweden
D	70FL15ZMONRZ	Nozzle .. Multi-Orifice - 1 1/2"/38mm Storz
D	70FL17ZMONRZ	Nozzle .. Multi-Orifice - 1 3/4"/44mm Storz
D	70FL20ZMONRZ	Nozzle .. Multi-Orifice - 2"/51mm Storz

This traditional aluminum nozzle is completely UV proof, light and very durable. The 1/2"/13mm diameter nozzle barrel is threaded to accept the nozzle tips of 1/4"/6mm and 3/8"/10mm.



**NOZZLE .. BARREL / STRAIGHT STREAM (ALUMINUM)**

	Part#	Description
A	70FL15ZBEBSTG	Nozzle .. Barrel / Straight Stream 1 1/2"/38mm Alum. BSP
A	70FL15ZBENHTG	Nozzle .. Barrel / Straight Stream 1 1/2"/38mm Alum. NH (NST)
A	70FL15ZBEPSTG	Nozzle .. Barrel / Straight Stream 1 1/2"/38mm Alum. NPSH
B	70FL15ZBEQCTG	Nozzle .. Barrel / Straight Stream 1 1/2"/38mm Alum. Forged QC
C	70FL15ZB-TIP	Nozzle Tip Aluminum Barrel 1/4"/6mm and 3/8"/10mm

This nozzle is light and very durable. The 1/2"/13mm nozzle barrel is threaded to accept the nozzle tips of 1/4"/6mm and 3/8"/10mm.



**NOZZLE .. BARREL / STRAIGHT STREAM (PLASTIC)**

	Part#	Description
A	70FL15ZBRNH	Nozzle .. Barrel / Straight Stream 1 1/2"/38mm Plastic NH (NST)
A	70FL15ZBRPS	Nozzle .. Barrel / Straight Stream 1 1/2"/38mm Plastic NPSH
B	70FL15ZBRQC	Nozzle .. Barrel / Straight Stream 1 1/2"/38mm Plastic, Forged QC
B	70FL15ZBRQDC	Nozzle .. Barrel / Straight Stream 1 1/2"/38mm Plastic, Die Cast QC
C	70FL15ZBR-TIP	Nozzle Tip Plastic Barrel 1/4"/6mm and 3/8"/10mm

3/4"/19mm brass straight stream and shut-off nozzle to fit on any garden hose thread and comes with an integral permanent gasket.



**BRASS MINI NOZZLE (GHT MODEL)**

Part#	Description
6012001	Mini-Nozzle 3/4"/19mm for Garden Hose



**COLLAPSIBLE TANKS**

Part#	Description
70FLTC500	500 Imp gal. / 602 US gal. / 2275L. Dimensions 90" x 40" (229 x 102 cm)
70FLTC1000	1000 Imp gal. / 1202 US gal. / 4545L. Dimensions 116" x 40" (295 x 102 cm)
70FLTC1700	1700 Imp gal. / 2045 US gal. / 7730L. Dimensions 134" x 54" (340 x 137 cm)
70FLTC2500	2500 Imp gal. / 3007 US gal. / 11,365L. Dimensions 156" x 54" (396 x 137 cm)

**OPTIONAL**

Part#	Description
70FLTC-GSHEET10	Ground Sheet 10'x 10' (3.05M x 3.05M) to fit 2,275 liter tank
70FLTC-GSHEET12	Ground Sheet 12'x 12' (3.67M x 3.67M) to fit 4,545 liter tank
70FLTC-GSHEET15	Ground Sheet 15'x 15' (4.57M x 4.57M) to fit 7,730 liter tank
70FLTC-GSHEET17	Ground Sheet 17'x 17' (5.18M x 5.18M) to fit 11,365 liter tank

Rugged and reinforced polyvinyl UV resistant material. The tank is self-supporting through the use of a flotation collar. The maximum height is 40"/102cm to 54"/137cm for convenient water shuttle use. Standard colour is yellow. Outlets, located at ground level, are 3.0"/76mm female PVC c/w PVC plug.



**HYDRO-WICK® "FIREFLYER" HELICOPTER TANKS**

Part#	Description
70FLTH60	Fireflyer Helicopter Tank (72 US Gal., 273 Liters)
70FLTH110	Fireflyer Helicopter Tank (132 US Gal., 500 Liters)

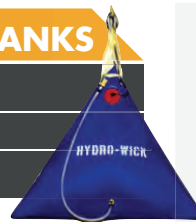

These aerodynamic Hydro-Wick® Fireflyers are used extensively by the forestry service to transport water, foam or potable water to remote locations by helicopter. The compact, flexible containers are made from a tough PVC coated fabric. Supplied complete with a 4"/102mm filler, shut-off at the outlet, standard GHT hose with "O" ring for attaching to harness clip and special pear shaped ring to resist rollout.



**PORTA SLIP-ON™**

Part#	Description
70FLTT110	Totally enclosed collapsible water tank. 110 US gal. / 416 Liters
70FLTT150	Totally enclosed collapsible water tank. 150 US gal. / 570 Liters
70FLTT110-KITA	Porta Slip-on Kit (Basic) .. Comes complete with 110 US gal. / 416 Liters collapsible water tank, Ball valve, Short suction hose, Ground sheet, and Carrying bag
70FLTT110-KITB	Porta Slip-on Kit (Complete) .. Includes 70FLTT110-KITA components, plus WICK 100M pump, 25'/7.6M of rubber covered 1 1/2"/38mm QC coupled hose, 1"/25mm Fog / straight stream nozzle, thread protector and required Adaptors.
70FLTT150-KITA	Porta Slip-on Kit (Basic) .. Comes complete with 150 US gal. / 570 Liters collapsible water tank, Ball valve, Short suction hose, Ground sheet, and Carrying bag
70FLTT150-KITB	Porta Slip-on Kit (Complete) .. Includes 70FLTT150-KITA components, plus WICK 100M pump, 25'/7.6M of rubber covered 1 1/2"/38mm QC coupled hose, 1"/25mm Fog / straight stream nozzle, thread protector and required Adaptors.
70FLTC-BAG	Carrying bag for Collapsible Reservoir Tanks
70FLTC-GSHEET	Ground Sheet for Collapsible Reservoir Tanks (4' x 6' / 1.2M x 1.8M)

Also available with other pumps and threaded connections

- First of a kind, box style tank concept to replace bulky hard walled tanks.
- Complete kit components fit neatly into the carrying bag for easy storage and rapid deployment
- The sturdy collapsible tank can be filled from either the top filler cap or by reverse flow into the discharge connection.
- Ideal for forestry and municipal fire services, or back-up fire contractors in fighting grass and brush fires
- The kit price savings can be adapted to mix and matches with various combinations of our portable fire pumps, hoses and nozzles
- Complete kit components fit into carrying bag. Total kit weighs approximately 25Kg / 55 lbs
- Custom size kits available, e.g. ATV's



Corrosion proof tank made with UV resistant-polyethylene plastic. Heavy wall thickness provides high puncture resistance and all but eliminates low impact damage. The large diameter filler neck is equipped with a replaceable flexible plastic mesh strainer and closed off by a friction fit, very leak resistant rubber cap with built in one way breather. Weather resistant synthetic rubber filler cap and collar. Features a unique swivel connection between the tank and hand pump which allows either left or right hand operation. Pump hose connection swivels 90 degrees, which keeps space requirement to a minimum when transporting.



**POLY TANK™ RIGID BACK TANK**

Part#	Description
70FLBTR5KIT	Rigid Poly Back Tank complete c/w hand pump .. 5 gal US / 19L
70FLBTR5KITSP	Rigid Poly Back Tank econo style .. no swivel connection, no spray spring
70FLBTR5MAN	Rigid Poly Back Tank Manitoba style .. 5 gal US / 19L c/w heavy duty padded straps
70FLBTR5	Rigid Back Tank .. 5 gal US / 19L, less hose and hand pump

**OPTIONAL**

	Part#	Description
A	70FLBTR5-1884	Rubber Cap for Rigid Back Tank
B	70FLBTR5-HANDLE	Handle with gripper clips
B	70FLBTR5-1917	Handle only (less gripper clips)
C	70FLHPUMP-B	Hand Pump for Rigid / Collapsible Back Tank (Hose sold separately)
C	70FLHPUMP-F	Hand Pump for Rigid Back Tank (With Hose .. no fitting)
C	70FLHPUMP-W	Hand Pump for Rigid Back Tank, Wajax style (with hose + 3/8"/10mm Female NPSH fitting)
D	70FLBTR5-1285	Strainer Assembly for Rigid Back Tank
E	70FLBTR5DRKIT	D Ring Assembly kit
F	70FLBTR5-GRIP	C-clip for Rigid Back Tank
G	70FLBTR5-ELBOW	Elbow assembly Rigid Back Pack
H	70FLBTR5-STRAP	Straps Non-Padded for Rigid Back Tank (1/2 Set) .. 2 req'd
I	70FLBTR5-STRAPC	Straps Padded for Rigid Back Tank (1/2 Set) .. 2 req'd
J	70FLBTR5-BASE	Base Support Bracket for Rigid Back Tank .. C/W Straps

A high quality cotton/synthetic bag complete with liner, designed to feed out hose as the carrier walks. Capacity is either 4 lengths cotton/synthetic or 5 lengths synthetic hose. Optional rigid cardboard storage box



**HOSE BAG SELF-LAYING**

Part#	Description
70FLBAGSL	Bag, Hose Self-Laying
70FLBAGSL-BOX	Rigid cardboard storage box .. 21" x 10" x 18" (53 x 25 x 46cm)

Sewn from mildew resistant canvas and capable of storing and transporting 500'/152M of 1 1/2"/38mm fire hose.



**HOSE BAG CARRYING**

Part#	Description
70FLBAGC	Bag, Hose Carrying



**BACK TANK, COLLAPSIBLE**

Part#	Description
70FLBTC5KIT	Back Tank, Collapsible (5 Gal US / 19L) c/w hand pump
70FLBTC5KITQC	Back Tank, Collapsible (5 Gal US / 19L) c/w Quebec style hand pump
70FLBTC5	Back Tank, Collapsible XR5 (5 Gal US / 19L) .. tank & strap only



OPTIONAL

	Part#	Description
A	70FLHPUMP	Hand Pump for Collapsible Back Tank (with Hose & GHT fitting)
B	70FLHPUMP-G	Hand Pump for Back Tanks (Male GHT, no hose)
C	70FLBTC5-STRAP	Harness for Collapsible Back Tank (Includes 2 straps & cross strap)
D	6404TF12GM	Adaptor 1/4"/6mm NPT Female to 3/4"19mm GHT Male
E	6404TM04TMCLS	Close Nipple 1/4"/6mm NPT Brass
F	6406SSPF08B	Brass Swivel Female 3/8"/10mm NPSH x 1/2"/13mm Barbed Fitting
G	70FLBTC5QCM	Connector Male GHT x Quick Connect
H	70FLBTC5QCF	Connector / Valve Female GHT x Quick Connect
I	70FLBTC5RPKIT	Repair Kit for Collapsible Back Tank
N/A	70FLBTC5RRKIT	Repair Kit. Incl. Filler Cap, Gasket & 3/4"19mm Discharge Adaptor

The most advanced collapsible backpack with the following design features:

- "UV" resistant, highly visible PVC coated polyester fabric
- Total operational weight under 55 lbs / 25Kg
- Capacity 5 gal. US (19 liters)
- Foam grade PVC allows for use with Class A foam
- Quick disconnect fitting to a brass hand pump c/w shut off
- Adjustable carrying strap c/w cross strap
- Heavy duty, long life brass hand pump



**IN-LINE PRESSURE TEST GAUGE**

Part#	Description
70METG15NH	In-Line Pressure Test Gauge 1 1/2"/38mm NH (NST)
70METG15PS	In-Line Pressure Test Gauge 1 1/2"/38mm NPSH
70METG15BS-S	In-Line Pressure Test Gauge 1 1/2"/38mm BSP BSP Male-Male
70METG15QC	In-Line Pressure Test Gauge 1 1/2"/38mm FQC

In-line pressure gauge, liquid filled, measures water pressures along a hose line, 600 PSI /41 Bar.



**IN LINE PRESSURE RELEASE VALVE**

Part#	Description
70FLRVBS	In-Line Pressure Relief Valve - 1 1/2"/38mm BSP
70FLRVNH	In-Line Pressure Relief Valve - 1 1/2"/38mm NH (NST)
70FLRVPFBM	In-Line Pressure Relief Valve - 1 1/2"/38mm NPSH Female x BSP
70FLRVPS	In-Line Pressure Relief Valve - 1 1/2"/38mm NPSH
70FLRVQC	In-Line Pressure Relief Valve - 1 1/2"/38mm Forged QC
70FLRV-1340	In-Line Pressure Relief Replacement Valve (Without Coupling)

Designed to protect hose lays from pressures beyond requirements. This valve is installed at any point in a 1 1/2"/38mm discharge hose lay and will automatically reduce excess pressures via an adjustable, automatic pressure bleed off 3/4"/19mm Male GHT outlet. This is designed to allow the attachment of a 3/4"/19mm Myti-Flo® hose to keep the area dry. Aluminum, brass and stainless steel construction. Connections are available in NPSH, NH and QC. Other options are also possible.



# PACKLITE™

Lightweight, ergonomic & multifunctional hosepack



### Construction

- Made of highly resistant, waterproof materials
- Multiple slots for the straps
- The backpack has a rigid aluminum alloy structure and a flexible container

### Features

The bag design allows the hose to be deployed as you approach the fire, so that the hose does not snag when walking and is laid out in the safest access area. This system allows a single person to advance the hose lay from the pump to the fire and beyond.

With the bag closed, you can also carry other types of loads such as clothing and helmets, etc. The bag can be removed from the structure to carry other products, such as fire pumps and accessories, etc. Multiple slots for the straps allow the backpack to be adjusted to each person's comfort, lumbar support and load balance.

### Weight & Dimensions (Frame + Harness)

Weight: 6.6 lbs (3.0 kg)      Height: 25.6" (65 cm)  
 Width: 15.0" (38 cm)      Depth: 12.1" (30.8 cm)



**C**  
HARNES



**D**  
LOAD STRAPS



**E**  
BAG STRAP



**WICK® 375 CARRYING PACK**  
(Call for quote)



**WICK® 100 SERIES CARRYING PACK**  
(Call for quote)

Part #	Description
A 70FLMPF	PackLite™, includes aluminum frame, bag, load straps, and harness assembly
B 70FLMPF-BAG	Bag only, for back pack
C 70FLMPF-HARNES	Harness only, for back pack
D 70FLMPF-STPFRAME	Front straps, for back pack (One male and one female)
E 70FLMPF-STPTBAG	Top strap, for bag



CONTINUED NEXT PAGE ..



Proven, cost effective Class A foam making systems for urban and wildland firefighting operations. Superior range Class A foam nozzles of 11, 23, 34, 50 and 60 US gpm / 41, 86, 128, 188, 226 LPM. Variable round-the-pump foam proportioned for flows of 150 gpm / 564 LPM or less. Fixed flow inline inductor with companion air aspirating nozzle. The "Blizzard Wizard®" line of products will convert any 1 1/2"/38mm hose into an "initial attack line" capable of throwing 600 gpm / 2256 LPM of foam up to 75'/23M.

**BLIZZARD WIZARD® FOAM MAKING PRODUCTS**

Nozzle	Flow Capacity	Quantity of foam	Reach @ 100 psi / 6.9 Bar
A	Suitable for hand pump	20-40 gpm / 76-152 lpm	
B	11 gpm / 42 lpm	110 gpm / 416 lpm	45 feet / 14 Meters
C	23 gpm / 87 lpm	230 gpm / 869 lpm	50 feet / 15 Meters
D	34 gpm / 129 lpm	340 gpm / 1285 lpm	70 feet / 21 Meters
E	50 gpm / 189 lpm	500 gpm / 1890 lpm	75 feet / 23 Meters
F	60 gpm / 227 lpm	600 gpm / 2268 lpm	75 feet / 23 Meters

	Part#	Description
A	73BW-1000	Foam Nozzle: Mini-Mousse 3/4"/19mm (for Back Pack Fire Ext.)
A	73BW-1000-DBS	Foam Nozzle: Mini-Mousse 1/4"/6mm (for DB Smith Pumps)
A	73BW-1000-GHT	Foam Nozzle: Mini-Mousse 3/4"/19mm (Garden Hose Thread)
B	73BW-1002	LF-8 Foam nozzle c/w 3/4"/19mm GHT
C	73BW-1003	MF-16 Foam nozzle c/w 1 1/2"/38mm NPSH
C	73BW-1003-NH	MF-16 Foam nozzle c/w 1 1/2"/38mm NH (NST)
C	73BW-1003-QC	MF-16 Foam nozzle c/w 1 1/2"/38mm QC
D	73BW-1004	HF-32 Foam nozzle c/w 1 1/2"/38mm NPSH
D	73BW-1004-NH	HF-32 Foam nozzle c/w 1 1/2"/38mm NH (NST)
E	73BW-1005	SF-50 Foam nozzle c/w 1 1/2"/38mm NPSH
E	73BW-1005-NH	SF-50 Foam nozzle c/w 1 1/2"/38mm NH (NST)
F	73BW-1006	SF-60 Foam nozzle c/w 1 1/2"/38mm NPSH
F	73BW-1007	SF-60 Foam nozzle c/w 1 1/2"/38mm NH (NST)
I	73BW-1009	Suction Tee Adaptor, 1 1/2"/38mm NPSH (for use with model BB mixer)
I	73BW-1010	Suction Tee Adaptor, 2"/51mm NPSH (for use with model BB mixer)
No photo	73BW-1010-G	Suction Tee Adaptor, 2"/51mm NPSH less GHT fitting (for use with model BB mixer)
H	73BW-1011	Dischg T adpt, 1 1/2"/38mm GHT for BB mixer (with samp. nozz.)
K	73BW-1011-H	Dischg T adpt, 1 1/2"/38mm GHT for BB mixer (no samp. nozz.)
H	73BW-1012	Dischg T adpt., 1 1/2"/38mm NPSH for BB mixer (with samp. nozz.)
J	73BW-1012-B	Dischg T adpt., 1 1/2"/38mm NPSH for BB mixer (male GHT only)
K	73BW-1012-H	Dischg T adpt., 1 1/2"/38mm NPSH for BB mixer c/w cap & chain (no samp. nozz.)
J	73BW-1013-B	Dischg T adpt., 1 1/2"/38mm female NPSH x 1 1/2"/38mm male NH for BB mixer (male GHT only)
L	73BW-1015	BB Foam Mixer Var. Round-the-Pump Proportioner
No photo	73BW-1017	Loss of pump prime preventor - Valve only
No photo	73BW-1018F	Loss of pump preventor - Cap only - FIRETOL
No photo	73BW-1018S	Loss of pump prime preventor - Cap only - SILV-EX
No photo	73BW-1022	Thread Adpter for booster nozzle 1 1/2"/38mm NH male 1"/25mm NH female
G	73BW-1030	Inline foam eductor (NPSH - for use with 73BW-1006)
G	73BW-1031	Inline foam eductor (GHT - for use with 73BW-1007)
No photo	6406TM12GFHEX	3/8"/10mm Brass Adaptor NPT male x 3/4"/19mm GHT female Hex



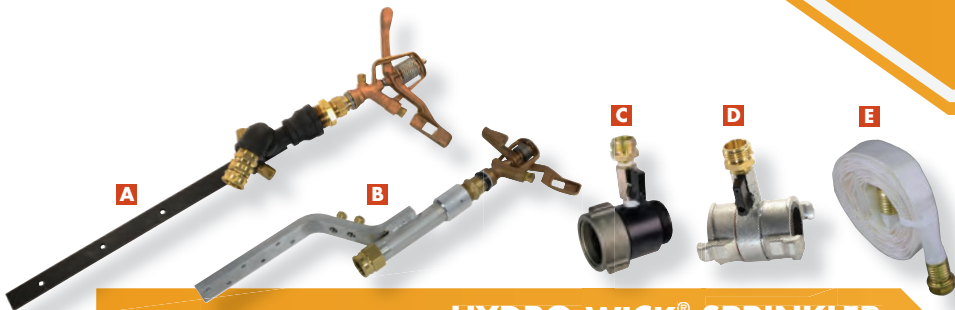

**HYDRO-WICK® SPRINKLER**

	Part#	Description
A	70FLSP-R	Sprinkler Head and Spike
B	70FLSP-MAN	Sprinkler Head and Spike (Manitoba model)
A + C + E	70FLSPKITNH	Sprinkler Kit .. Sprinkler Head and Spike, 15'/4.6m of Myti-Flo Hose, & NH Water thief
A + C + E	70FLSPKITPS	Sprinkler Kit .. Sprinkler Head and Spike, 15'/4.6M of Myti-Flo Hose, & NPSH Water thief
A + D + E	70FLSPKITQC	Sprinkler Kit .. Sprinkler Head and Spike, 15'/4.6M of Myti-Flo Hose, & QC Water thief
A + D + E	70FLSPKITQCDC	Sprinkler Kit .. Sprinkler Head and Spike, 15'/4.6M of Myti-Flo Hose, & QC (die cast) Water thief

A heavy duty model that is designed for use with standard forestry fire pumps. The high performance sprinkler is excellent for use on prescribed burns and on exterior building as well as fire line protection. Supplied with splitter type nozzle. Mounting holes are provided and standard models are fitted with GHT swivel female threads for use with our standard Myti-Flo® 3/4"/19mm hose and standard water thief.

**OPTIONAL**

	Part#	Description
F	70FLSP2000SX	Sprinkler Head only -No Spike
G	70FLSP0202	Sprinkler Nozzle 1/4"/6mm Male NPT x 1/4"/6mm Tip
G	70FLSP0302	Sprinkler Nozzle 1/4"/6mm Male NPT x 3/16"5mm Tip
G	70FLSP0402	Sprinkler Nozzle 1/4"/6mm Male NPT x 1/8" 3mm Tip
G	70FLSP0502	Sprinkler Nozzle 1/4"/6mm Male NPT x 5/32" 4mm Tip
G	70FLSP18P12K	Sprinkler Nozzle 3/16" / 4.76mm Male NPT x 3/16" / 4.76mm Tip (Storm)
H	6412GF12GFSV	Swivel Connector, 3/4"/19mm GHT Female to 3/4"/19mm GHT Female
I	6404TMPLGH	1/4" / 6mm NPT Hexagon Brass Plug
J	70FLSP-4174	Sprinkler base sub-assembly (Manitoba style)

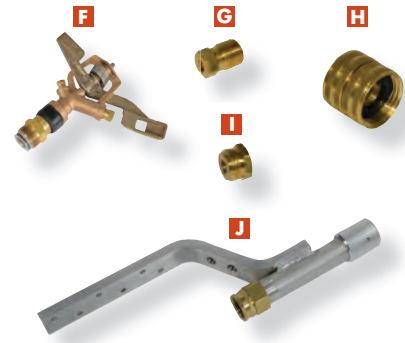

**HYDRO-WICK® ROOT SOAKER**

Part#	Description
70FLRS	Root Soaker .. 45" / 1.14M total length, c/w 10'/3M of Myti-Flo coupled hose

A heavy duty model designed for use with standard forestry fire pumps. Standard models are fitted with GHT swivel female threads for use with our Myti-Flo® 3/4"/19mm hose and water thief. Designed to fight against re-ignition from underground hot spots. Penetrates soil to "wet-out" subterranean hot spots with its' high pressure nozzles. High pressure ball valve provided for flow control and shut-off. Foam hand grips 10'/3M of coupled Myti-Flo® 3/4"/19mm hose included.



**DRIP TORCH**

Part#	Description
70FLDRTCH-R	Drip Torch 5 Liter (Contact factory for parts)
70FLDRTCH1L-R	Drip Torch 1 Liter (Contact factory for parts)

Constructed from light weight and long lasting aluminum with safety features such as a check valve, fuel trap, and a self-extinguishing igniter when the unit is in an upright position. The wand reverses for convenient and leak proof storage within the reservoir. Available in 1 liter (0.26 US gal.) and 5 liter (1.32 US gal.) sizes.



Specifically designed to clean forestry and municipal hose, these economical tools are compact, simple and very effective. Angled water jets accomplish the cleaning and aid in feeding the hose through the washer.

The 1 1/2"/38mm inch hose washer cleans up to 1 1/2"/38mm hose equipped with threaded rocker lug or quarter turn fittings.

The 3"/76mm hose washer cleans up to 3"/76mm hose equipped with threaded rocker lug.

The 4"/102mm hose washer cleans up to 4"/102mm hose equipped with threaded rocker lug.

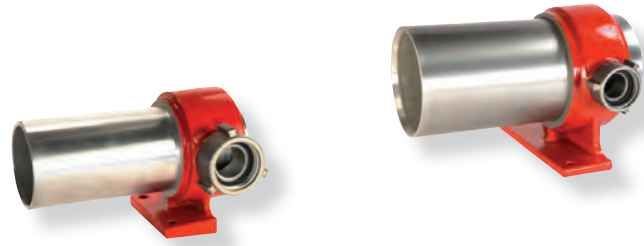

### HYDRO-WICK® HOSE WASHERS

Part#	Description
70FLHW15BS	1 1/2"/38mm BSP connection (Cleans up to 1 1/2"/38mm coupled hose)
70FLHW15NH	1 1/2"/38mm NH connection (Cleans up to 1 1/2"/38mm coupled hose)
70FLHW15PS	1 1/2"/38mm NPSH connection (Cleans up to 1 1/2"/38mm coupled hose)
70FLHW30NH	1 1/2"/38mm NH connection (Cleans up to 3"/76mm coupled hose)
70FLHW30PS	1 1/2"/38mm NPSH connection (Cleans up to 3"/76mm coupled hose)
70FLHW30BS	1 1/2"/38mm BSP connection (Cleans up to 3"/76mm coupled hose)
70FLHW40PS	1 1/2"/38mm NPSH connection (Cleans up to 4"/102mm coupled hose)

Engineered specifically for use on 1"/25mm and 1 1/2"/38mm fire hoses to momentarily;

- Interrupt water flow
- Alter hose lays
- Change nozzles
- Add water thieves, sprinkler systems, etc.

- Blue anodized for greater visibility
- Engineered for lighter weight.
- Offered with agency engraving in our recessed Identify® slot



### HYDRO-WICK® HOSE STRANGLERS

	Part#	Description
A	70FLHSCLPNL	Straight Hose Strangler (Anodized blue)
B	70FLHSCLPNL-Q	Straight Hose Strangler .. Quebec style (Anodized blue)
C	70FLHS-2782	Rubber insert for Hose Strangler



### OPTIONAL

Part#	Description
70FLHSBLT	Hose Strangler Belt
70FLHSPCH	Hose Strangler Pouch
70FLHSPBH	Hose Strangler Belt, Pouch combo



### HYDRO-WICK® COUPLING WRENCH

Part#	Description
70FL15CPWR	Coupling Wrench
70FLUCPWR	Universal 2 1/2" / 64mm to 6" / 152mm Coupling wrench

This unique (aluminum alloy) coupling wrench is designed for use on 1 1/2"/38mm and 2"/51mm forestry quick connect or threaded couplings.

The universal coupling wrench is for use with rocker lug and pin lug couplings in sizes from 2 1/2" / 64mm to 6" / 152mm.

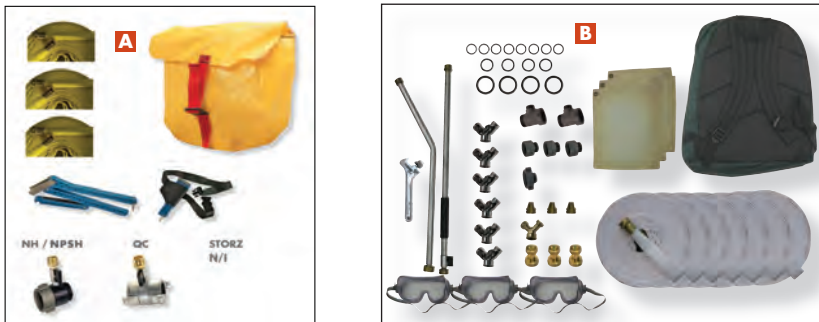

### HYDRO-WICK® MOP-UP KIT

	Part#	Description
A	70FLMOPKITNH	Mop - Up Kit , c/w NH water thief
A	70FLMOPKITPS	Mop - Up Kit , c/w NPSH water thief
A	70FLMOPKITQC	Mop - Up Kit , c/w QC water thief
A	70FLMOPKITQDC	Mop-Up Kit , c/w QC die cast water thief
A	70FLMOPKIT2ORZ	Mop - Up Kit , c/w 2"/51mm Storz water thief
B	70FLMOPKITGSA	Mop-Up Kit GSA (4210-01321-4206) .. with applicator (Specify Thread)

The kit consists of a carrying pouch complete with three 3/4"/19mm x 50'/15M length of "Myti-Flo" hose, a 3/4"/19mm GHT nozzle, a gated water thief, a hose clamp c/w pouch and web-belt.

### OPTIONAL

Part#	Description
70FLMOPBAG	Mop-Up kit pouch
70FLMOPAP	Mop-Up kit applicator (GSA)



### HYDRO-WICK® JACK STACK

Part#	Description
70FLATOWNH	Hydro-Wick Jack Stack reducing adaptors from 2 1/2"/64mm NH to GHT threads
70FLATOWPS	Hydro-Wick Jack Stack reducing adaptors from 2 1/2"/64mm NPSH to GHT threads

This handy stack of adaptors provides reducing combinations from 2 1/2" / 64mm down to GHT threads.



## PART NUMBER DESCRIPTION

FOLLOW THESE 4 STEPS TO FIND THE COUPLING OF YOUR CHOICE

1. GO TO OUR WEBSITE [WWW.MERCEDESTEXTILES.COM](http://WWW.MERCEDESTEXTILES.COM)
2. CHOOSE THE DESIRED FIRE HOSE
3. FROM THE HOSE MENU SELECT THE DIAMETER
4. SCROLL DOWN TO FIND THE COMPATIBLE COUPLINGS ASSIGNED TO THIS HOSE DIAMETER

## COUPLINGS FIELD REPAIRABLE

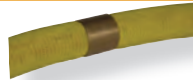

Part#	Description
5112GH16SKIT	Alum 3/4" (19mm) GHT for 1" (25mm) Boostlite / crimped (Price per Set)
5112GH12FR	Boostlite Field Repairable Shank 3/4" (19mm) GHT
5116FR16FR	Boostlite Field Repairable Shank splice unit 1" (25mm)
5116NH16FR	Boostlite Field Repairable Shank 1" (25) NH
5116PS16FR	Boostlite Field Repairable Shank 1" (25) NPSH
5116BS16FR	Boostlite Field Repairable Shank 1" (25) BSP
5124PS24FR	Boostlite Field Repairable Shank 1 1/2" (38mm) NPSH
5124NH24FR	Boostlite Field Repairable Shank 1 1/2" (38mm) NH
5124TM24FR	Boostlite Field Repairable Shank 1 1/2" (38mm) NPT

5132TM32FR	Boostlite Field Repairable Shank 2" (51mm) NPT
5112FR12FR	Boostlite Field Repairable Shank splice unit 3/4" (19mm)
5116FR16FR	Boostlite Field Repairable Shank splice unit 1" (25mm)
5116NH12FR	Boostlite Field Repairable Shank 3/4" x 1" (25 x 19mm) NH
5116PS12FR	Boostlite Field Repairable Shank 1" x 3/4" (25 x 19mm) NPSH
5112FRSPCP	Factory Installed Compression Splice 3/4" (19mm)
5116FRSPCP	Factory Installed Compression Splice 1" (25mm)
5124FRSPCP	Factory Installed Compression Splice 1 1/2" (38mm)
5132NH32FR	Boostlite Field Repairable Shank 2" (51mm) NH
5132PS32FR	Boostlite Field Repairable Shank 2" (51mm) NPSH

## COUPLINGS BRASS THREADED ALUM. THREADED QUICK CONNECT



## COUPLINGS CAM AND GROOVE HIGH PRESSURE SNOW HOSE



## COUPLINGS SWEDISH MERLUG QC

PART NUMBER	DESCRIPTION
5224SW16SA	Alum. Coupling 1 1/2" Swedish QC Cplg x 1" Shank Assembled (Price each .. two req'd)
5224SW24SA	Alum. Coupling 1 1/2" Swedish QC Cplg x 1 1/2" Shank Assembled (Price each .. two req'd)





**PART NUMBER    DESCRIPTION**

FOLLOW THESE STEPS TO FIND THE DESIRED ADAPTOR

- 1. GO TO OUR WEBSITE [WWW.MERCEDESTEXTILES.COM](http://WWW.MERCEDESTEXTILES.COM)
- 2. CLIQUE ON THE ADAPTOR SELECTOR MENU LOCATED AT THE TOP RIGHT
- 3. FILL IN THE DETAILS ON EACH DROPDOWN LIST FOR SIDE ONE FOLLOWED BY SIDE TWO

AS THE SELECTIONS ARE MADE THE LIST WILL SHRINK TO DISPLAY THE REQUIRED ADAPTOR

**ADAPTORS    ALUM. FORGED Q/C**



**ADAPTORS    ALUM. DIE CAST Q/C**



**ADAPTORS    ALUM. THREADED**





## ADAPTORS HIGH PRESS. SNOW HOSE

PART#	SIDE 1		SIDE 2	
6124SF24PF	1 1/2	Cam & Groove Female	1 1/2	NPSH Female (Part D)
6124SF24TF	1 1/2	Cam & Groove Female	1 1/2	NPT Female (Part D)
6124SF24TM	1 1/2	Cam & Groove Female	1 1/2	NPT Male (Part B)
6124SM24PF	1 1/2	Cam & Groove Male	1 1/2	NPSH Female (Part A)
6124SM24TF	1 1/2	Cam & Groove Male	1 1/2	NPT Female (Part A)
6124SM24TM	1 1/2	Cam & Groove Male	1 1/2	NPT Male (Part F)
6132PF32SM	2	NPSH Female	2	Cam & Groove Male (Part A)
6132SF24PF	2	Cam & Groove Female	1 1/2	NPSH Female (Part D)
6132SF24TF	2	Cam & Groove Female	1 1/2	NPT Female (Part D)
6132SF32TF	2	Cam & Groove Female	2	NPT Female (Part D)
6132SF32TM	2	Cam & Groove Female	2	NPT Male (Part B)
6132SM24PF	2	Cam & Groove Male	1 1/2	NPSH Female (Part A)
6132SM24TF	2	Cam & Groove Male	1 1/2	NPT Female (Part A)
6132SM32TF	2	Cam & Groove Male	2	NPT Female (Part A)
6132SM32TM	2	Cam & Groove Male	2	NPT Male (Part F)
6140SF40TM	2 1/2	Cam & Groove Female	2 1/2	NPT Male (Part B)
6140SM40TF	2 1/2	Cam & Groove Male	2 1/2	NPT Female (Part A)

## SWEDISH MERLUG QC

PART#	SIDE 1		SIDE 2	
6216PF24SWA	1	NPSH Female	1 1/2	Swedish
6216PM24SWA	1	NPSH Male	1 1/2	Swedish
6224PF24SWA	1 1/2	NPSH Female	1 1/2	Swedish
6224PM24SWA	1 1/2	NPSH Male	1 1/2	Swedish



## PLASTIC THREADED

PART#	SIDE 1		SIDE 2	
6616NF24NM	1	NH Female	1 1/2	NH Male
6616PF24PM	1	NPSH Female	1 1/2	NPSH Male



## TANDEM ADAPTORS

PART#	SIDE 1		SIDE 2	
70FL15TABS	2	NPSH	1 1/2	BSP Sw Female
70FL15TANH	2	NPSH	1 1/2	NH Sw Female
70FL15TAPS	2	NPSH	1 1/2	NPSH Sw Female
70FL15TAQC	2	NPSH	1 1/2	Forged QC



## THREAD PROTECTOR

PART#	SIDE 1		SIDE 2	
70FL15TPPS	1.5"	NPSH Female	1.5"	NPSH Male
70FL20TPPS	2"	NPSH Female	2"	NPSH Male



## FACE GASKETS

## TAIL GASKETS

PART#	DESCRIPTION
5912FG	Washer Garden Hose
5916FGNH	Face Gaskets 1" - NH Thread
5916FGPS	Face Gaskets 1" - NPSH Thread
5924FGNH	Face Gaskets 1 1/2" - NH (NST) Thread
5924FGPS	Face Gaskets 1 1/2" - NPSH Thread
5924FGQC	Face Gaskets 1 1/2" Quarter-Turn
5924FGRZ	Face Gaskets 1 1/2" STORZ RED HEAD
5924FGRZG	Face Gaskets 1 1/2" STORZ
5924FGSN	Face Gaskets 1 1/2" Snow Hose / Cam & Groove
5924FGSNR	Face Gaskets 1 1/2" Snow Hose / Cam & Groove (Red Nat. Rubber)
5932FG	Face Gaskets 2" NPSH
5932FGLS	Face Gaskets 2" For Long Shank Cplg's
5932FGRZ	Face Gaskets 2" STORZ
5932FGSN	Face Gaskets 2" Snow Hose / Cam and Groove
5932FGSNR	Face Gaskets 2" Snow Hose / Cam and Groove (Red Nat. Rubber)
5940FG	Face Gaskets 2 1/2"
5940FGNH	Face Gasket 2 1/2" NH (NST) Swivel
5940FGQC	Face Gaskets 2 1/2" Quarter-Turn
5940FGRZ	Face Gaskets 2 1/2" STORZ Standard
5940FGRZ-R	Face Gaskets 2 1/2" STORZ Red Head
5948FGRZ	Face Gaskets 3" STORZ Standard
5964FGNH	Face Gasket 4" NH (NST) Swivel
5964FGRZ	Face Gasket 4" Storz
5980FGNH	Face Gasket 4" NH (NST) Swivel
5980FGRZ	Face Gasket 5" Storz
6624i24RZ	1 1/2" PLASTIC INSERT FOR 1 1/2" STORZ
6640i40RZ	2 1/2" PLASTIC INSERT FOR 2 1/2" STORZ

PART#	DESCRIPTION
5916TG19	Tail Gasket 1" to fit 1 5/32" bowl
5924TG27	Tail Gasket 1 1/2" to fit 1 11/16" bowl
5924TG28	Tail Gasket 1 1/2" to fit 1 3/4" bowl
5924TG29	Tail Gasket 1 1/2" to fit 1 13/16" bowl
5924TG31	Tail Gasket 1 1/2" to fit 1 15/16" bowl
5928TG32	Tail Gasket 1 3/4" to fit 2" bowl
5928TG34	Tail Gasket 1 3/4" to fit 2 1/8" bowl
5932TG35	Tail Gasket 2" to fit 2 3/16" bowl
5928TG36	Tail Gasket 2" to fit 2 1/4" bowl
5932TG37	Tail Gasket 2" to fit 2 5/16" bowl
5932TG38	Tail Gasket 2" to fit 2 3/8" bowl
5940TG43	Tail Gasket 2 1/2" to fit 2 11/16" bowl
5940TG44	Tail Gasket 2 1/2" to fit 2 3/4" bowl
5940TG46	Tail Gasket 2 1/2" to fit 2 7/8" bowl
5940TG48	Tail Gasket 2 1/2" to fit 3" bowl
5948TG53	Tail Gasket 3" to fit 3 5/16" bowl
5948TG53-S	Tail Gasket 3" to fit 3 5/16" bowl (Action)
5964TG70	Tail Gasket 4" to fit 4 3/8" bowl
5980TG86	Tail Gasket 5" to fit 5 3/8" bowl



## BRASS EXPANSION RINGS

PART#	DESCRIPTION
5916RG1242	Brass Expansion Ring 1" x 3/4"
5916RG1442	Brass Expansion Ring 1" x 7/8"
5916RG1742	Brass Expansion Ring 1 x 1 1/16"
5916RG2042	Brass Expansion Ring 1" x 1 1/4"
5924RG1242	Brass Expansion Ring 1 1/2" x 3/4"
5924RG1442	Brass Expansion Ring 1 1/2" x 7/8"
5924RG1742	Brass Expansion Ring 1 1/2" x 1 1/16"
5924RG1949	Brass Expansion Ring 1 1/2" x 1 3/16"
5924RG2049	Brass Expansion Ring 1 1/2" x 1 1/4"
5928RG1950	Brass Expansion Ring 1 3/4" x 1 3/16"
5928RG2050	Brass Expansion Ring 1 3/4" x 1 1/4"

PART#	DESCRIPTION
5932RG2050	Brass Expansion Ring 2" x 1 1/4"
5932FGRZ	Brass Expansion Ring 2" Storz
5932RG2450	Brass Expansion Ring 2" x 1 1/2"
5939RG2063	Brass Expansion Ring 2 7/16" x 1 1/4"
5939RG2363	Brass Expansion Ring 2 7/16" x 1 7/16"
5939RG2463	Brass Expansion Ring 2 7/16" x 1 1/2"
5948RG32	Brass Expansion Ring 3" x 2"
5964RG32	Brass Expansion Ring 4" x 2"
5972RG32	Brass Expansion Ring 4 1/2" x 2"
5980RG32	Brass Expansion Ring 5" x 2"



A well balanced tool and ideally suited for light cutting tasks such as line spotting. Conforms to the specifications FFES HT-3 as published by the CCFM/FFEWG 95.



## FIRE AX

Part#	Description
70HTFAS	Single Bit axe
70HTFASH	Replacement handle
70HTFAD	Double Bit axe
70HTFADH	Replacement handle

This single or double - edged bush hook is designed for heavy duty clearing and scrubbing of tough vines, weeds, undergrowth and small saplings. Head is approximately 1/4" thick.



## BUSH HOOK (PRODUCT DISCONTINUED)

Part#	Description
70HTBHSC	Single-edged bush hook
70HTBHSH	Straight replacement handle
70HTBHDS	Double - edged bush hook
70HTBHDH	Curved replacement handle

A tough and solid raking tool, useful in the removal of brush and duff layers. Handle length meets USDA spec.



## MCLEOD TOOL

Part#	Description
70HTMT	McLeod tool
70HTMTH	Replacement handle

Used mainly for smothering and extinguishing grass fires, Fire Swatters are also used for "mopping up" after brush fires. Field tested and proven over many years. The 12" W x 15" L rubber flap is first attached to a steel frame, then secured to a 60" ash handle with ferrule.



## FIRE SWATTER

Part#	Description
70HTSW	Fire Swatter
70HTSWH	Replacement handle
70HTSWF	Replacement flap



**FIRE RAKE**

Part#	Description
70HTFR	Fire Rake
70HTFRT	Replacement Tines C/W Rivets
70HTFRHD	Replacement Head C/W Tines
70HTFRH	Replacement Handle for Fire Rake (60"/152cm)

Designed for the removal of light duff and litter layers in hardwood and pine stands. This tool was designed by professional fire fighters to withstand rough service. The rake is removable for easy transport and storage. Handle length meets U.S.D.A. specification.



**COLLAPSIBLE FIRE RAKE™**

Part#	Description
70HTFR-C	Collapsible Fire Rake
70HTFR-5708	Replacement Tines for Collapsible Fire Rake

The collapsible fire rake is made of light weight, high strength aluminum and is designed with ease of transportation, versatility and durability in mind. The rakes' stainless steel tines fold in easily for transportation and lock into place when fanned out to any required position. Used by the US Forestry Service . (NSN #4210-01-387-1392 / NFES #0659).



**FIRE SHOVEL**

Part#	Description
70HTFS	Fire Shovel
70HTFSH	Replacement handle for fire shovel

A specially designed shovel for fire fighting purposes. The design conforms to the specifications FFES HT-4 as published by the CCFM/FFEWG 95.



**PULASKI**

Part#	Description
70HTPU	Pulaski
70HTPUH	Replacement handle for pulaski
70HTPUD	Replacement head for pulaski
70HTPUF	Pulaski c/w 36" fiberglass handle

This combination ax/mattock tool has been manufactured to the specifications FFES HT-1 as published by the CCFM/FFEWG 95. Meets U.S.D.A. specification.



## HOSE PATCHING KIT

Consists of 20 hose patches, adhesive and hardener. This repair method involves a cold patching procedure as opposed to a vulcanization method.

Part#	Description
70MEHPKIT	Hose Patching Kit
70MEPATCH	Hose Patches only, package of 20 beveled patches

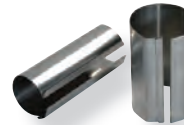

## EMERGENCY REPAIR SLEEVE

Fabricated from stainless steel. Designed to temporarily stop leaks in fire hose and to indicate damaged areas for later repairs.

Part#	Description
70FL10RPSL	Emergency Repair Sleeve 1"
70FL15RPSL	Emergency Repair Sleeve 1 1/2"



## TOOL BOX

Solid construction. Color is red powder coated. Spacious tray and nickel plated latches. Dimensions 20" x 8 1/2" x 9 1/2" (51mm x 21.5mm x 24mm)

Part#	Description
70METBOX	Tool Box



## HAND HYDRAULIC EXPANDER

Part#	Description
70MEHHEXP	Hand hydraulic expander
70MEEHEXP	Electric hydraulic expander

## OPTIONAL

Part#	Description
70ME10DB	1" /25mm drawbar only (no segments)
70ME10DBS	1" /25mm drawbar assembly c/w segments
70ME10DBSM	1" /25mm drawbar assembly c/w segments plus 5 1/2" (14cm) Adaptor
70ME10SEG	1" /25mm segments only
70ME10SEGH	1" /25mm segments holder
70ME15AR	1 1/2" /38mm adjusting ring
70ME15DBS	1 1/2" /38mm drawbar assembly c/w segments
70ME15DBSCAM	1 1/2" /38mm drawbar assembly c/w segments (Cam & Groove)
70ME15SEG	1 1/2" /38mm segments only
70ME15SEGH	1 1/2" /38mm segments holder
70ME17DBS	1 3/4" drawbar assembly c/w segments
70ME17DBS-RZ	1 3/4" Storz drawbar assembly c/w segments
70ME17SEG	1 3/4" segments only
70ME20DBS	2" /51mm drawbar assembly c/w segments
70ME2015DBS	2" /51mm x 1 1/2" /38mm drawbar assembly c/w segments for use with 2" & 1.75" couplings requiring a ring length of 1 1/4" or less
70ME20DBSCAM	2" /51mm drawbar assembly c/w segments (Cam & Groove)
70ME25DBS	2 1/2" /64mm drawbar assembly c/w segments
70ME25SEG	2 1/2" /64mm segments only
70ME3025DBS	3" /76mm x 2 1/2" /64mm drawbar assembly c/w segments

Ideal for low to moderate hose coupling needs. Portable and requires no external power. Effective and simple to operate.



## EXPANSION RING REMOVER

Part#	Description
70MEEXREM	Expansion ring remover

A tooth like tool to be inserted between the coupling wall and the expansion ring to remove an expansion ring prior to reusing a coupling.





Repair kit for 4 stage pumps. Comes complete with all tools shown here. Call our factory for detailed instructions how to dis-assemble and re-assemble the 4 stage pump.



**4 STAGE PUMP REPAIR KIT**

Part#	Description
79T-KIT	Repair Kit for FSP4200 4 stage pump end

**OPTIONAL**

	Part#	Description
1	79W-1665P	Shaft Nut Wrench
2	79T-1313	Shaft Protector
3	79T-1963	Seal Installation Tool
4	79T-1964	Impeller & Distributor Removal Tool
5	79T-1965	Shaft Fitting Base
6	79T-1966	Pump Body Support
7	79T-1967	Shaft Removal Pin
8	79T-1208	Distributor Assembly Tool
9	79T-1207	Puller 4 Stage Pump
10	5932RG2450	Brass Expansion Ring
11	79T-2706	Seal Removal Tool
12	79T-2709	Bearing Press Removal Tool

This tool kit includes the basic tools required to perform field maintenance of our WICK® line of portable fire pumps.

**PUMP TOOL KIT**

Part#	Description
70METKIT	Pump Maintenance Tool Kit

**OPTIONAL**

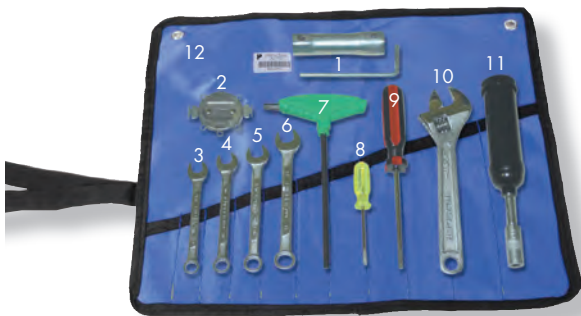

	Part#	Description
1	78T-SPKW-1316	Spark plug wrench 13/16" / 1"
2	78T-SPKG	Spark plug feeler gauge
3	78T-CW06	3/8" Combination Wrench
4	78T-CW10M	10 mm Combination Wrench
5	78T-CW07	7/16" Combination Wrench
6	78T-CW13M	13 mm Combination Wrench
7	78T-AT06M	Allan Key T-Handle 6mm x 6"
8	78T-SF02-2.4	Screwdriver Flat Head 1/8" x 2 3/8"
9	78T-SF04-4	Screwdriver Flat Head 1/4" x 4"
10	78T-AW8	8" / 20cm adjustable wrench
11	78T-B1933	Grease Gun
12	78T-PCH6	Tool Pouch



### WICK® 375 PUMP TOOL KIT

Part#	Description
71W37-TKIT	Wick 375 Tool Kit

#### OPTIONAL

	Part#	Description
1	78T-CW8M	8 mm Combination Wrench
2	78T-CW10M	10 mm Combination Wrench
3	78T-CW13M	13 mm Combination Wrench
4	78T-SF04-4	Screwdriver Flat Head 1/4" x 4"
5	78T-ATO6M	Allan Key T-Handle 6mm x 6"
6	78T-SPKW-1316	Spark plug wrench 13/16" / 1"
7	78T-PCH6	Tool Pouch

This tool kit comes standard with our WICK® 375 line of portable fire pumps.



### WICK® 250 PUMP TOOL KIT

Part#	Description
71W25-TKIT	Wick 250 Tool Kit

#### OPTIONAL

	Part#	Description
1	78T-CW07	7/16" COMBINATION WRENCH
2	78T-CW08	1/2" COMBINATION WRENCH
3	78T-CW06	3/8" COMBINATION WRENCH
4	78T-SF04-4	Screwdriver Flat Head 1/4" x 4"
5	78T-SPKW-1213	Spark plug wrench 13/16" / 3/4"
6	78T-PCH6	Tool Pouch

This tool kit is optional with our WICK® 250 line of portable fire pumps.



### PUMP TEST KIT

Part#	Description
70MEPTSTQC	Pump Test Kit c/w QC fittings
70MEPTSTNH	Pump Test Kit c/w NH fittings
70MEPTSTPS	Pump Test Kit c/w NPSH fittings

#### OPTIONAL

Part#	Description
70 METBOX	Tool Box
70 MECN-1355	Calibrated Nozzle 1/8" diameter
70 MECN-1357	Calibrated Nozzle 1/4" diameter
70 MECN-1358	Calibrated Nozzle 5/16" diameter
70 MECN-1359	Calibrated Nozzle 3/8" diameter
70 MECN-1360	Calibrated Nozzle 7/16" diameter
235070031C	Myti-Flo® 3/4"/19mm x 3'/0.9M coupled
160150101C	Fire Stop 1 1/2"/38mm x 10'/3M coupled
70METG15QC	In Line Pressure Test Gauge
70FL15ZBAQCTO	1 1/2" QC Straight Stream Alum Nozzle

This pump test kit provides the basic essentials to accurately measure the performance of high pressure fire pumps. The kit contains 5 calibrated nozzle tips, a straight stream nozzle, short lengths of 3/4"/19mm and 1 1/2"/38mm hose, pressure gauge and tool box.





## Terms and conditions of sale

### Shortages or Damaged Merchandise

Any shortage, damage or error in shipment should be reported to us immediately upon receipt of good and at the latest within 10 days after delivery. All packages should be carefully inspected for visible damage prior to acceptance, and delivery refused or damage noted when signing for receipt of packages.

### Returned Goods

If there is a need to return goods, please contact our customer service department with full details concerning the reason for return of any goods. The customer service will issue a Return Goods Authorization number (RGA), which should be indicated with the return goods shipment. Material being returned for credit will carry a minimum of a 20% handling and restocking charge. Goods must be in new and original condition subject to inspection, and returned freight prepaid. Note: Non-standard items are non-returnable for credit.

### Warranties

Mercedes Textiles Limited offers a limited warranty on items manufactured by Mercedes Textiles Limited as described below under "defects in material", and disclaims liability for the following:

- Failure of the product if it is used for other than its intended purpose.
- Changes or modifications not expressly approved by Mercedes Textiles.
- Unreasonable use, supplemental damage, or damage to the product not resulting from defects in material or workmanship.
- Any personal injury, damage to property, or any incidental or consequential damages of any kind resulting from misuse, improper installation, negligence, repair, or alteration of the product.

Note: Mercedes Textiles makes no warranty with respect to any item non-manufactured by it. The buyer is subject only to any such warranty made by these respective manufactures, and to the extent available to the buyer.

### Defects in Material

Mercedes Textiles guarantees all merchandise manufactured by Mercedes Textiles to be free from defects in material and/or workmanship for a period of one (1) year from date of invoice (See pump manuals for limitations on hours of use, etc.). Any item believed to contain a defect must be returned to Mercedes Textiles for examination and evaluation. If the merchandise is defective, Mercedes Textiles will repair or replace the defective item and reimburse the buyer for reasonable transportation charges.

### Limitations about this catalogue

The products described in this catalogue, including without limitation, product features, specifications, designs, pricing, and availability, are subject to change by Mercedes Textiles and its subsidiaries at any time without notice. This catalogue and other information from Mercedes Textiles, its subsidiaries, and its authorized distributors, provides product options for further evaluation by users with technical expertise. It is essential that the user analyzes all facets of the proposed product application

and review the information on the product in the current product catalogue. Due to the wide variety of operational conditions and applications for these products, the user, by their own analysis and tests, is solely responsible for making the final selection of the product and for assuring that all performance, safety and warning requirements for the particular application are met.

### Ordering Information

Our distributors are located worldwide. Please contact us or go to our website at to request the distributor nearest you.

### Training Courses Offered

We offer training courses in the following categories:

- Fireline operating procedures for power pumps
- Repair and maintenance of portable fire pumps
- Basic Forest Fire Fighting

Training courses are offered in classroom and field environments with a hands-on, certified S100 instructor.

Our courses can be given either in our classroom facilities or at a remote location anywhere in the world.

### Our Patents

- Mertex Wayout® coupling (US 9,539,449; Canada 2,753,087; South Africa 2011/06223; UK 2,480,968). Other patents pending
- IReflect® high visibility lock lever (US 9,895,562; US 10,493,306; Canada 2,772,960; China ZL201090001151.4). Other patents pending
- Identify® recessed area for couplings (China ZL201220060166.9; Germany 20 2012 100 577.8). Other patents pending
- MERLITE™ lightweight coupling with protective shoulder (US 9,103,474; Canada 2,808,486).
- Fuel can adaptor (Canada 2,853,322; US 9,505,602). Other patents pending
- Breather technology™ for fire hose (US 9,752,707; Canada 2,865,920)
- Plus other patents pending in several countries

### Notations

1. UL denotes Underwriters Laboratory USA and ULC denotes Underwriters Laboratory of Canada.
2. FM denotes Factory Mutual
3. ® Represents registered trademarks of Mercedes Textiles, unless otherwise noted
4. ™ Represents trademarks of Mercedes Textiles or High-Water Hose Inc., unless otherwise noted
5. All our hoses meet or exceed all performance requirements of NFPA 1961, Underwriter's Laboratories and Factory Mutual.



<b>A</b>			
ADAPTORS FOR FIRE HOSE AND PUMPS	.....	56	
<b>B</b>			
BACK TANK, COLLAPSIBLE	.....	49	
BACK PACK (WICK PACKLITE)	.....	51	
BACK-BOARD (WICK 80, 100, 250)	.....	28	
BACK-BOARD (WICK 375, F200-10S)	.....	28	
BLIZZARD WIZARD®			
FOAM MAKING PRODUCTS	.....	51	
BOOSTLITE®	.....	43	
BUSH HOOK	.....	61	
<b>C</b>			
CHECK VALVE	.....	30	
COLLAPSIBLE FIRE RAKE HYDRO-WICK®	.....	62	
COLLAPSIBLE TANKS	.....	48	
COLLECTING HEAD 3 WAY	.....	43	
CONTROL PANEL B&S MODEL PUMPS	.....	28	
COUPLING WRENCH HYDRO-WICK®	.....	56	
COUPLINGS FOR FIRE HOSE	.....	57	
<b>D</b>			
DRAFTLITE®	.....	44	
DRIP TORCH	.....	54	
<b>E</b>			
ELBOW 90 DEGREES	.....	28	
EMERGENCY REPAIR SLEEVE	.....	63	
EXHAUST PRIMER B&S MODEL PUMPS	.....	28	
EXPANSION RINGS	.....	58	
EXPANSION RING REMOVER	.....	64	
<b>F</b>			
FIRE AXE	.....	61	
FIRE BOSS®	.....	40	
FIRE HOSES	.....	37	
FIRE RAKE	.....	62	
FIRE PUMPS	.....	3	
FIRE SHOVEL	.....	62	
FIRE STOP®	.....	41	
FIRE SWATTER	.....	61	
FIREBREAK II®	.....	39	
FIRELINE ACCESSORIES	.....	45	
FIREFLYER HELICOPTER TANKS	.....	48	
FOAM ACCESSORIES	.....	54	
FOOT VALVES / STRAINERS	.....	35-36	
FOOT VALVE ADAPTORS	.....	36	
FORESTGUARD II®	.....	41	
FORESTREAM®	.....	42	
FUEL TANKS	.....	32	
FUEL LINES	.....	32	
<b>G</b>			
GARDEN HOSE NOZZLE	.....	46	
GASKETS (FACE AND TAIL)	.....	60	
GATED WYE(S)	.....	46	
GREASE GUN PUSH TYPE	.....	25	
<b>H</b>			
HAND EXPANDER	.....	64	
HAND HYDRAULIC EXPANDER	.....	64	
HAND PUMP FOR BACK TANKS	.....	50	
HAND TOOLS	.....	61	
HAND PRIMER HYDRO-WICK®	.....	29	
HELICOPTER TANKS (FIREFLYER)	.....	48	
HOSE BAG CARRYING	.....	49	
HOSE BAG SELF LAYING	.....	49	
HOSE MAINTENANCE	.....	63	
HOSE PATCHING KIT	.....	63	
<b>HOSE STRANGLERS</b>	.....	55	
HOSE WASHERS HYDRO-WICK®	.....	55	
HYDRO-WICK® WEEPING PROCESS	.....	38	
<b>I</b>			
IN LINE PRESSURE TEST GAUGE	.....	50	
INLINE PRESSURE RELEASE VALVE	.....	50	
<b>J</b>			
JERRY CAN	.....	31	
<b>L</b>			
LIMITATIONS	.....	67	
LONG SHANK COUPLING	.....	36	
<b>M</b>			
MANIFOLD (4 PORT)	.....	29	
MCLEOD TOOL	.....	59	
MOP-UP KIT	.....	56	
MERTEX® LINING PROCESS	.....	36	
MYTI-FLO®	.....	43	
<b>N</b>			
NOZZLES (ALL MODELS)	.....	47	
<b>P</b>			
PERCOLITE™	.....	40	
PERMATEK HP™ HOSE JACKET REATMENT	.....	37	
PORTA SLIP-ON™ UNITS	.....	48	
POLY TANK™ RIGID BACK TANK	.....	49	
PRIMER / CHECK VALVE (POPPET)	.....	30	
PULASKI	.....	62	
PUMP ACCESSORIES	.....	27	
PUMP END 2 STAGE (F200™)	.....	27	
PUMP END 4 STAGE (FSP4200™)	.....	27	
PUMP MAINTENANCE	.....	65	
PUMP MOUNTING CLAMP	.....	27	
PUMP REPAIR KIT 4 STAGE	.....	65	
PUMP TEST KIT	.....	66	
PUMP TOOL KIT	.....	65	
PUMPS TWO & FOUR CYCLE	.....	3	
PUSH TYPE GREASE GUN	.....	27	
<b>Q</b>			
QUICK CONNECT COUPLING SYSTEM	.....	42	
<b>R</b>			
RIGID BACK TANK (POLY TANK™)	.....	49	
ROOT SOAKER HYDRO-WICK®	.....	54	
SPRINKLER HYDRO-WICK®	.....	54	
<b>S</b>			
SHUT-OFF VALVES	.....	46	
SLIP-ON UNITS	.....	26	
STORZ SHANK COUPLING	.....	35	
STRAPS FOR BACK BOARDS	.....	28	
STRAPS FOR BACK TANKS	.....	50	
SPRINKLER HYDRO-WICK®	.....	54	
SUCTION HOSES	.....	33	
SUCTION HOSE ACCESSORIES	.....	35	
<b>T</b>			
TERMS AND CONDITIONS OF SALE	.....	67	
TOOL BOX	.....	63	
THREE WAY COLLECTING HEADS	.....	45	
THREE WAY DIVERTER VALVES	.....	45	
TRAINING COURSES OFFERED	.....	67	
<b>W</b>			
WARRANTIES	.....	67	
WATER THIEF (HOSE LINE "T")	.....	45	
WICK® FIRE PUMPS	.....	1-27	
WYE COUPLING	.....	42	





INNOVATION DELIVERED.™



**MERCEDES  
TEXTILES LIMITED**  
Innovation delivered.™

5838 CYPHOT SAINT LAURENT  
QC, CANADA, H4S 1Y5

PHONE 514.335.4337 / 877.937.9660

FAX 514.335.9633

[mercedestextiles.com](http://mercedestextiles.com)  
[sales@mercedestextiles.com](mailto:sales@mercedestextiles.com)

[mercedestextiles.com](http://mercedestextiles.com)